

# MODEL RAILWAY

# EXPRESS

eMAGAZINE



**Issue nineteen:**  
**December 2019/January 2020**

*For the enthusiast by the enthusiast*

# EDM Models new website

[WWW.NGTRAINS.COM](http://WWW.NGTRAINS.COM)

Specialising in Narrow Gauge, mostly 7mm/ft but including other scales and useful products for all

## TOWNSEND HOOK

Our new 3D printed 0-16.5 loco body kit is now available.

3D printed body, roof etc, brass detail castings, wires other detail bits included.

Requires a Dapol 00 B4 chassis to complete



**£95**

**£8.50  
a bag**



**Sculptamold  
Lightweight  
Scenery  
Modelling  
Compound**

Sign Up for our Online Newsletter via our web page for the latest news & bargains.



**3D Printed On30  
Hopper Wagons  
£45 for a box of 3**

**Whilst Stocks Last**



**EDM MODELS**

19 Briar Avenue, Acomb, York, YO26 5BX  
01904 331973

[info@ngtrains.com](mailto:info@ngtrains.com)

[www.ngtrains.com](http://www.ngtrains.com)

# Contents

## REGULARS

Welcome to Issue 19.....	4
Railway Refreshments:The Final Whistle, Southwell.....	66
Railway Refreshments - International! Franschoek Station Pub & Craft Bar.....	140
A Day in the life of....Santa!.....	154

## GENERIC MODELLING

Something useful from a few leftover bits!.....	6
Soundtraxx announces new 21 pin mobile decoder.....	124
“When you’re on the outside Looking In...” Thoughts on Great Central Railway’s Exhibition.....	126
Lightweight Scenery.....	162

## WORLDWIDE MODELLING

Big Steam, Narrow Steam and Shiny Nails - Part 3.....	10
Winelands Light Railway - One Man’s Railway.....	42
Big Steam, Narrow Steam and Shiny Nails Part 3 - contin- ued.....	96

## BRITISH MODELLING

The Midland Region in the 1970s and 1980s.....	28
Chew Magna - Part 3.....	32
Freight in the Peak District.....	44
Second Generation DMUs.....	48
Midlands Model Engineering Exhibition 2019 Review.....	52

### Cover photo

*Due to unforeseen strike action by his reindeer, Santa has had to settle for alternative  
delivery methods*

*(Photo by Dave Chamberlain)*

## BRITISH MODELLING (continued)

London Model Engineering Exhibition 2020.....	62
The 1896 Light Railways Act.....	72
The Station Master's Apartment, Strathcarron.....	106
Railways at Night, From dusk til dawn.....	116
Midlands Garden Rail Show.....	120
Large Scale Tram Models to Operate at Crich.....	152

## NARROW GAUGE MODELLING

Hopefield Branch - part 3.....	36
Hill's Tramroad - Blaenavon World Heritage Site.....	58
Railcars.....	80
Paul's On30 page - making the most of your flat cars.....	146

*Happy Christmas  
to all our readers*



Your  
advert  
here

To advertise in  
Model Railway Express  
please contact

[Terence.Rowe@drmeypublishing.com](mailto:Terence.Rowe@drmeypublishing.com)



07875961273

## Welcome to Issue 19



Well, here we are at the end of the year again. At the risk of sounding old; it goes so quickly, it only seems like it was summer 5 minutes ago!

We hope you enjoy this latest issue of MRE Mag. Our new cover photographer has had fun creating this issue's picture and 'Day in the Life of...' is suitably seasonal this time around, too.

And if you're in South Africa as you read this, or are planning a trip soon, do try and fit in the Winelands Light Railway (more on that in future issues).

If you're at a bit of a loose end after the holiday period why not write an article for MRE Mag? We'd be particularly interested in anything on the modelling you're doing. It's always great to share what's gone well and even the lessons from anything that turned out not so well. Or have you been out and about and discovered somewhere that our readers might also like to go? Or just some feedback on the magazine; what do you like, what would you like to see more of? Please send all contributions to [editor@MRE-mag.com](mailto:editor@MRE-mag.com). We'd love to hear from you.

In the meantime we'd like to wish all of our readers a happy and peaceful Christmas and New Year.

Enjoy Issue 19 - we'll be back in 2020!

*The MRE team*

---

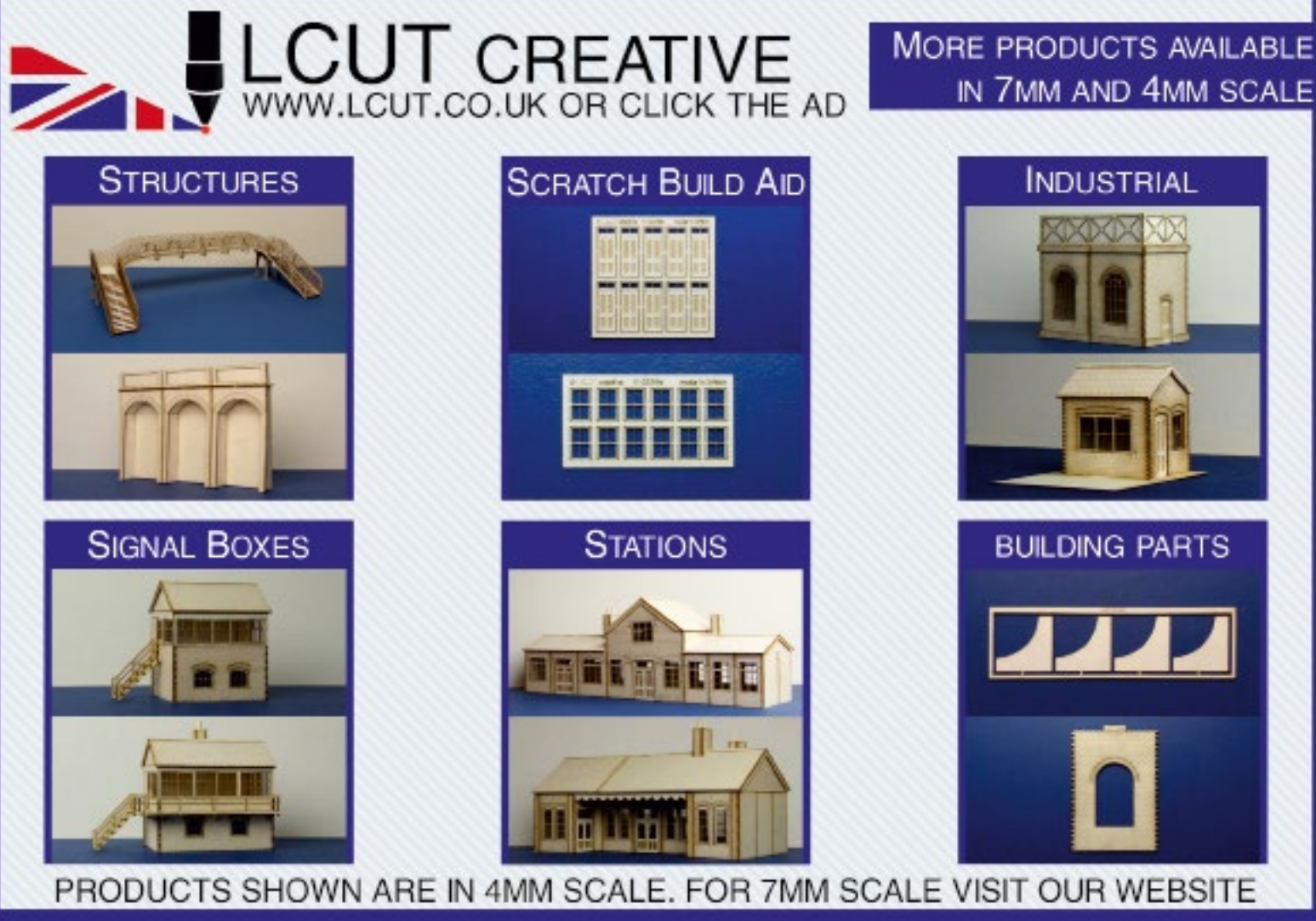

The advertisement banner features a blue background with a white diagonal line pattern. At the top left is a logo consisting of a stylized pencil and a Union Jack flag. To the right of the logo, the text reads "LCUT CREATIVE" in large, bold, white letters, with "WWW.LCUT.CO.UK OR CLICK THE AD" in smaller white text below it. In the top right corner, a dark blue box contains the text "MORE PRODUCTS AVAILABLE IN 7MM AND 4MM SCALE" in white. The main body of the banner is divided into seven categories, each with a title and two images of the product:

- STRUCTURES**: Shows a curved bridge-like structure and a three-arched building facade.
- SCRATCH BUILD AID**: Shows two sheets of pre-cut wooden parts, one with a grid of small rectangular pieces and another with a grid of larger rectangular pieces.
- INDUSTRIAL**: Shows a two-story industrial building with a gabled roof and a smaller, single-story industrial building.
- SIGNAL BOXES**: Shows two different designs of signal boxes, one with a staircase and a balcony.
- STATIONS**: Shows two different designs of railway stations, one with a gabled roof and another with a flat roof and a canopy.
- BUILDING PARTS**: Shows a sheet of pre-cut wooden parts with curved shapes and a single arched window frame.

At the bottom of the banner, the text reads "PRODUCTS SHOWN ARE IN 4MM SCALE. FOR 7MM SCALE VISIT OUR WEBSITE" in white.

# Something useful from a few leftover bits!

By Rob Bradford

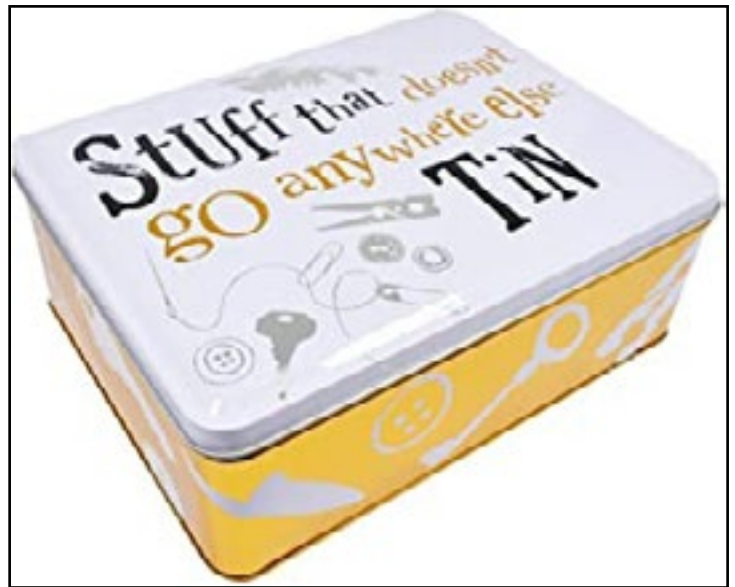

LED's (Light Emitting Diodes), initially 5mm in diameter and larger, have over time shrunk to today's sub-millimetre surface mount components.

If like me you have been dabbling with LED's for a while you are bound to have a few of the larger ones knocking about. I know I certainly did.

So in true Blue Peter style with the addition of a couple of resistors and two paperclips I decided to make something useful; A DC layout track tester and polarity indicator. Sounds complex? Not really, I even got my ten-year-old god son to make one for his layout.

The circuit is basically to pairs of LED's each consisting of a red and a green LED wired back to back, and a couple of current limiting resistors.



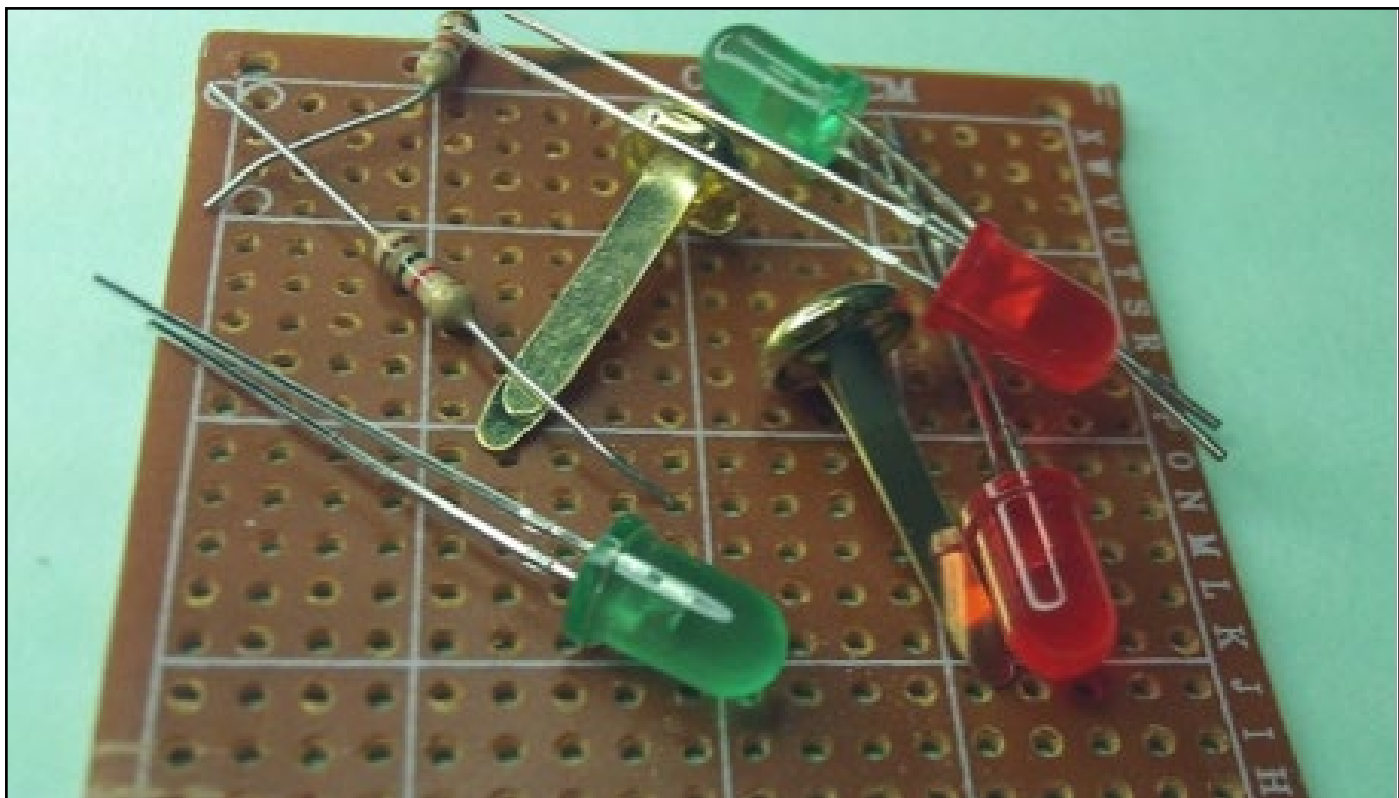

*Four LEDs two each of contrasting colours (red and green in this case), two resistors (1k), two Paperclips, Vero or development Board*

This will not be technical, I promise!

- Solder the paperclips track width apart.
- Fit a red LED with the long leg soldered to one of the paperclips,
- Fit a green LED with the short leg soldered to the same paperclip.
- Join one end of a resistor and the free legs of the LED's together, solder the other end of the resistor to the other paperclip!
- Next do the same again, soldering the two remaining LED's to the opposite paperclip, red long leg to

paperclip, green short leg to paperclip.

- Again join one end of the second resistor and the two free legs of the LED's together.
- Solder the free end of the second resistor to the other paperclip

IT'S DONE!

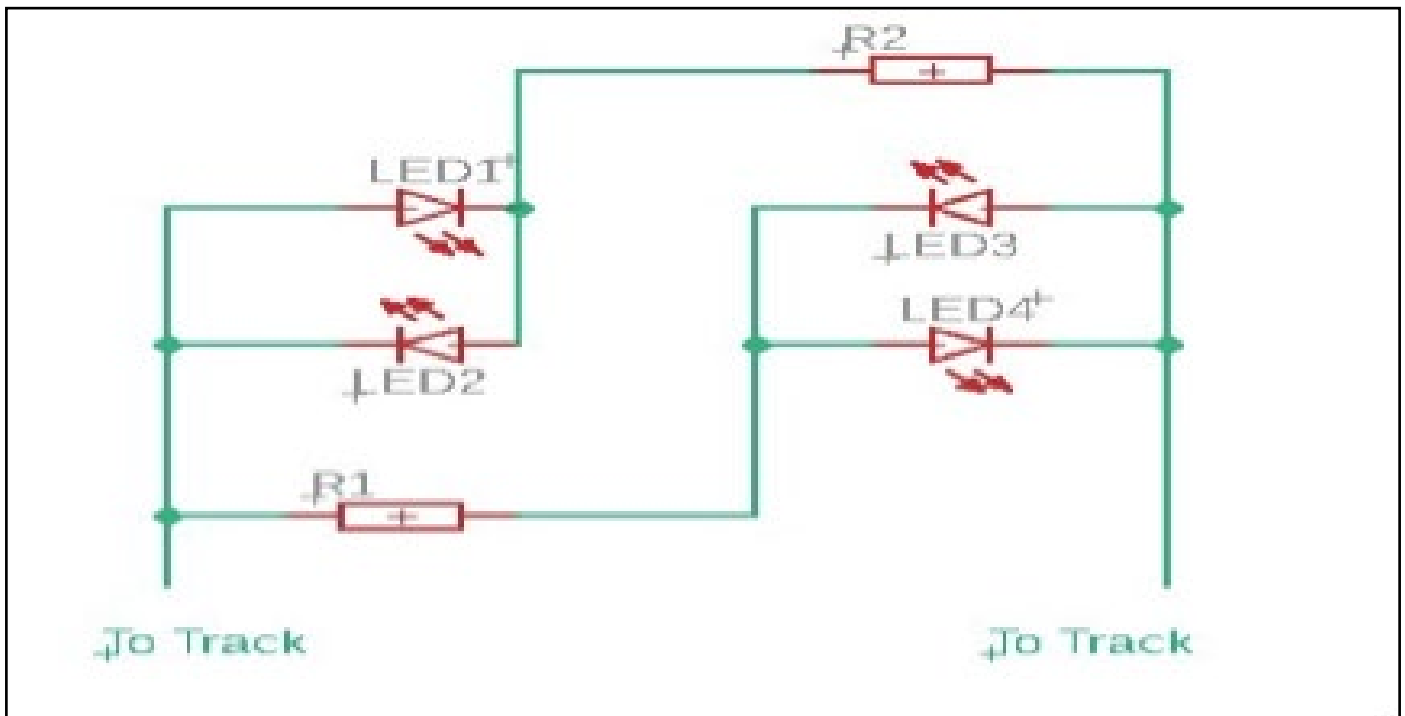

*The build*

Sorry for not being too technical, anodes and cathodes and all that, but I just wanted to show basic electronics is easy.

Have a go!

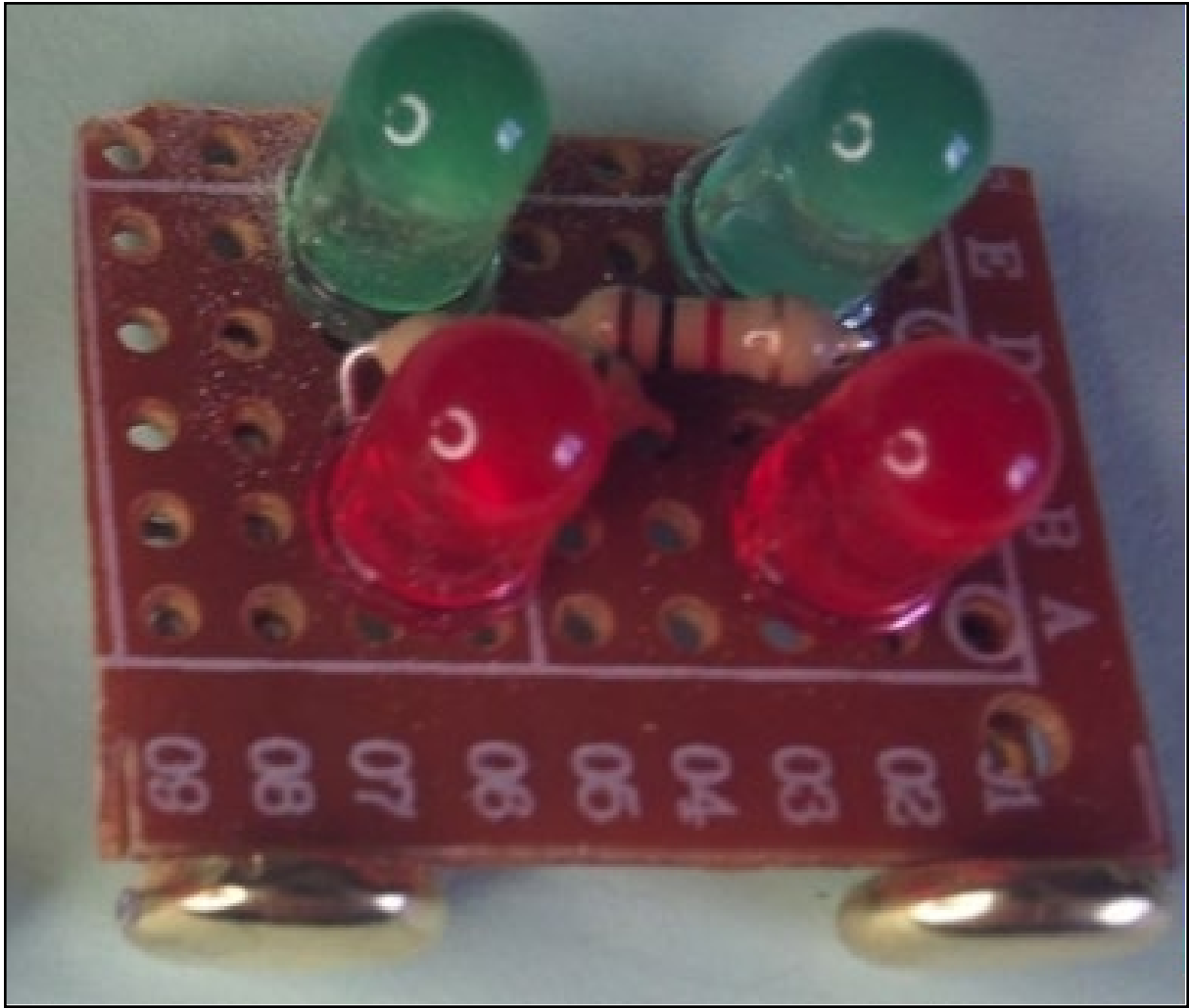

*LEDs caption One of the Red LED's will light to indicate the positive rail, and a green will indicate the ground or negative rail.*

---

**[www.blackhamtransfers.com](http://www.blackhamtransfers.com)**

*for the best dry transfers*

## Big Steam, Narrow Steam and Shiny Nails - Part 3

By; Martin Ford, Mike Ford, Mike Hewitt & Gerry Howard



**May 17<sup>th</sup>** - After breakfast we headed out, on foot, to find the sister engine to #168. T12 #169 was mounted on a plinth under a large open sided structure just in front of City Hall. The problem with weather and vandal protection is that they both inhibit photography due to support pillars, fences etc being in the way. We did the best we could but were pleased she is protected. One of the notice boards located near the locomotive had details of the old depot and museum, so we set off to find out more. The old depot was located just a few more blocks away and housed the visitor information centre. The lady behind the counter offered copious advice and was keen to help with information. We found out that the Rio Grande Scenic was another railroad that doesn't start operating until Memorial Day, which falls Monday after last weekend in May, (prospective travelers please note). While we were in the depot an EMD

F45PH in Rio Grande Scenic colours rumbled through the station.



*The four with Maurice at Colorado Gators, Mosca CO  
(Colorado Gators)*

Departing Alamosa we headed north, arriving in Mosca CO. No railways here, but a rescue home for Alligators and other reptiles which had come to rescue after they had been illegally bought, trafficked or grown too big for their owners. The tortoise fences (planks laid long-ways on the thin end) had to be negotiated. There was an opportunity to cuddle an Alligator, called Maurice - real but not too big! and we each received a certificate

of bravery endorsed by the smaller gator who used his jaws as a sort of ticket clipper. There was quite a diversity of inhabitants, Boas', Lizards and of course Alligators. There was a story attached to every one of them. Most were rescued from illegal owners, some had just grown too big to look after, some had escaped, some had been picked up wandering down the freeway and some were out of work film extras such as Morris - a 10 ft + {500 lb} gator who had starred in a number of films. Outside in the larger ponds were gators of all sizes, some Albino's and all content to bask in the sun. We headed further North back through Salida to re-visit the model shop to collect some stuff that we had forgotten from the previous visit, then onwards to Canon City CO for tomorrows trip on the Royal Gorge Route. Having found some accommodation pretty quickly, we then went down to the Depot to get the lie of the land for the following day. We noticed quite a few classic cars and hotrods cruising the Main Street, so after a few words with a Mustang owner we found out that there was a classic and custom car gathering (the 37<sup>th</sup> Annual Antique and Special Interest Car Show to give it it's full title) at the local 'abbey' tomorrow. We'll work it in somehow.

**May 18<sup>th</sup>** - Following the tip from the night before, we decided that it would be best to try and get to the car



*Our coach for the trip up the Royal Gorge CO  
(Martin Ford)*

show earlyish, bearing in mind we were booked on the 12.30 pm Royal Gorge train. A nice breakfast at a local café set us up for the morning. The cars in the queue to get in only wetted our appetite for what might be inside. After handing over our entrance money, a measly \$5 a head, we saw that there was a large sales/swap meet section for parts and car corral for the sale of vehicles. As we had less than two hours, we figured it was best to do the show field first as even if we could afford a bit of American metal it'd be a struggle getting it in the case... The sun was cracking and cars were

lined up like glistening sweets. An a-z of marques from the early 1910s Ford Model T's, right up current production Dodge Challenger's and Chevrolet Camaro's all awaited us. A modest trounce around, with a little extra loitering at the classic Mopars and an odd rain shower to boot, saw us cover the field just in time to head off to the depot to collect our tickets for the Royal Gorge excursion.



*The worlds highest suspension bridge viewed from the infamous Hanging Bridge CO (Mike Ford)*

Based upon advice from Steve Dennison, Black Diamonds chairman, we had pre-booked seats in one of the dome cars and pre-bought meal tickets. Our time



to board came and away we went to find our seats, south side end of car, at this time we weren't quite aware of how well we'd done. Our server was Bruce from Chicago, back on the train again after a little hiatus. We ordered pretty quickly and the food arrived before we had even set off, which in a way was good as it gave us more time to look at the scenery and wave to somewhat soggy white water rafters travelling in the opposite direction in the gorge below. On the return trip, a scheduled stop on the famous hanging bridge allowed views of the world's highest suspension bridge and gorge from the open-air car. Thankfully it was not showery at that time. Returning to Canon City we detrained and after a quick visit to the gift shop we headed back to the car show in time for the awards.

It had thinned out quite a bit due to the showers but the hard-core enthusiasts were still there as were quite a few of our personal favourites (vehicles). Given that spectator numbers had decreased we had greater access to the remaining exhibits. The overall winner was a Ford 'Woodie', but in total about a couple of dozen cars were recognised in their appropriate classes.

With the cars dispersed, it was on towards Georgetown CO. We had actually pre-booked accommodation in Dillon CO a few miles away and not only was it one of the nicest hotels we'd stopped in, it had a fantastic

overview of the lake formed by the Dillon Dam. We passed herds of Bison in fields on the journey and encountered heavy snow over the Hoosier Pass summit.

**May 19<sup>th</sup>** - Breakfast came and went and soon we were on the road. We were about 20 miles south of Georgetown, having had to compromise on closeness to the attraction against accommodation costs. The journey was uneventful, we lost several thousand feet in elevation as we descended into Georgetown passing the upper depot (Silver Plume) on the way. There was an engine in steam which would eventually become our road engine for the journey over the famous Georgetown Loop. We parked up and made our way to the depot, collected our tickets (booked on-line previously) and generally took in our surroundings and chatted with various railway personnel who were keen to introduce themselves to us. The train was brought down empty from Silver Plume by diesel power, a GE 44 tonner #1934 (originally standard gauge but converted) followed by the 2-8-0 #111 that was to be our power for the trip over the loop. It was then time to board and with our tickets presented, our seating allocated we found ourselves in the one of the parlour cars around table 27.



*#111 crossing Georgetown loop trestle with the second train of the day, Georgetown CO (Mike Ford)*

The steam power was attached, the diesel detached and dropped back further down the line. We were then advised that the train would also drop back so that it could get a better run at the grade. The diesel would follow up as a sort of disconnected DPU, just in case assistance was required as the train was fairly full. Following whistle signals between the two locomotives it was time to go and the steamer dug in and set off up the grade. Although the pace had dropped a little by the time we reached the iconic bridge (100' above the creek), the engine worked hard and we were

soon making steady process. Unfortunately we were in the third car back, and even allowing for the tight curves we couldn't fully keep the locomotive in sight. All the time the train was climbing there was information over the PA system and Jennifer our attendant supplied the necessary refreshment. After about 40 minutes we arrived at Silver Plume CO. Here the diesel was attached and the steamer detached. There is no facility to turn the steamer at Silver Plume, no wye tracks or turntable, which is why the return journey is operated in a reverse arrangement to the uphill one.



*Our steed for the journey over the Georgetown Loop, narrow guage 2-8-0 #111 backing down over the infamous trestle, Georgetown CO (Mike Hewitt.)*

On the downhill journey the train stopped at Lebanon Mine, to let off those passengers who had elected to add the mine tour to their itinerary. All too soon we were crossing the high bridge again and heading into the depot. It was time for our customary visit to the souvenir shop, before heading out to the beginning of the Georgetown trail (top side of the car park above the depot), to photograph the engine starting off on its second journey of the day with another train load of passengers. We loaded up and set off for Denver to our destination, the Forney Museum of Transportation. About an hour later we arrived and having secured our tickets set off to explore.

When we arrived the place was almost deserted but within 15 minutes there was a constant arrival of new visitors. Why were we at Forney? Well it is the home of #4005 another of the 8 preserved 'Big Boys'. Problem was that #4005 doesn't have the space she needs to be appreciated, such a big engine doesn't need to be sandwiched between a high platform and a UP rotary snow plough. It is nice that she is preserved and under cover, but how she is presented to the public was not ideal in our opinion. This is the same for all the railway exhibits. The Forney does not advertise itself as a railway museum, it deals with transportation in general and there was a display of 1980's American cars (this

was the main display which tends to be themed and changed quarterly), Indian motorcycles and other odds and sods - bicycles, some other motorcycles (primarily Honda's with a couple of Triumphs in the mix), a helicopter, light aircraft and a traction engine to name a few.



*UP #4005 in the Forney Transport Museum, Denver CO (Martin Ford)*

We were not overly impressed if the truth be known, but in all fairness, we had been spoiled up to this visit with good access to all we had tried to see and do. We exited to find a bite to eat and visit another model

shop (Caboose formerly Caboose Hobbies), which we found disappointing with hordes of empty shelves. Then a visit to Walmart for more additional luggage carrying capacity for the return journey. The evening was spent distributing purchases amongst all our group to ensure baggage weight limitations were not exceeded.

**May 20<sup>th</sup>** - After a good breakfast we headed off for Golden CO, home of the Colorado Railroad Museum. Even at 09.00 hrs the rush hour traffic was still fairly heavy as we made our way across Denver. The weather was overcast and rain threatened. The museum occupies about 15 acres with both standard and narrow gauge exhibits displayed outside around the site. Buildings include the main depot with a souvenir shop, administration facilities and a basement housing a large dual gauge (HO/HOn3) layout operated by the Denver HO modellers group. Other buildings include a reference library and the roundhouse. There is also a large scale 'garden/G gauge' railway outside to interest younger visitors. We headed outside to view the static displays which included narrow gauge Denver Leadville & Gunnison (DL&G) 2-8-0 #191, Rio Grande Southern (RGS) #74, D&RGW #50, shays; Argentine Central #14 & Westside Lumber Co (WSLc) #12, RGS galloping geese #2, #6 & #7 (3 of the remaining 6) - the standard gauge exhibits included Chicago Burlington &

Quincy (CB&Q) 4-8-4 #5629, D&RGW C28 #683, F9 A + B #5771 & 5762, SD40-2T tunnel motor #5401 and GP30 #3011.



*D&RGW EMD F9 #5771 at Colorado Railroad Museum, Golden CO (Mike Ford.)*

In addition to the motive power there were various narrow-gauge box and stock cars, tankers, cabooses and passenger equipment including business cars. Standard gauge exhibits included a rotary snowplough, scale test car, freight cars of more recent vintage and some UP coaching stock. The primary problem was





*DL&G #191 a diamond stacked narrow gauge 2-8-0 at Colorado Railroad Museum, Golden CO (Mike Ford)*

the weather, it was that fine rain that seems to really penetrate making you feel cold. We had to break off the outside exploration after about an hour and a half just to go back inside to warm up. Unfortunately, the museum does not do catering. There is no restaurant or snack bar, just cold drinks from vending machines which is not what we needed! We headed for the basement and the layout. It was large and well detailed, but not operating unless you fed a 'quarter' into the slot. We suspect though that on weekends and holidays it is manually operated with more to see.



RGS Goose #7 at Colorado Railroad Museum,  
Golden CO (Martin Ford)

We headed back outside to finish our survey of the exhibits. It wasn't any warmer but the light rain was more intermittent. We explored as far as was possible, display items with open doors, cabs etc were entered and examined, but an awful lot of the exhibits were not accessible. A lot of the external display items really do need better protection. As always due to the large number of items, it is not possible to work on them all and undertake the necessary protection and preservation. It is the same everywhere, there are only so many volunteers and a finite amount of money to distribute to all the needy preservation causes. It is a pity as some exhibits really do need work on them.

We headed off to find a suitable venue for lunch where we could dry out and get warm. We were advised by museum staff that Golden offered a number of such venues and set off to investigate. We were not disappointed. Golden is the headquarters of Coors, the brewing group and a substantial manufacturing (brewing) complex exists which is rail served. We saw a number of BNSF powered trains exiting the plant and also a number of ATSF cabooses dotted around the yard, but due to the weather we were less inclined to photograph these.



*RGS Gooses #2 & #6 on the turntable tracks at Colorado Railroad Museum, Golden CO (Martin Ford)*

By a stroke of luck at the place we ate, our server's husband was actually a rugby player and consequently on trips to the UK had learnt some of the lingo, chips not fries and that tea should be "English breakfast" rather than perfumed fruit.

We spent the afternoon in various model shops on the hunt for model railroad detail parts and any bargains that might be on offer. We must have visited about five in total with a subsequent burdening of various credit cards. The weather had deteriorated and was now sleet, subsequently becoming snow and by late evening the ground was covered. With an early check-in tomorrow for the internal flight back to Seattle, we hoped the weather would improve.

---

<p>O gauge redn and white metal kits</p>  <p>O gauge low-relief building facades. Picture shows SMRS38 3-storey north-light facades with added details.</p>	<h3>Skytrex Model Railways</h3> <p>Unit 1, Chamwood Business Park North Road Loughborough Leicestershire LE11 1LE</p> <p><a href="http://www.ogauge.co.uk">www.ogauge.co.uk</a> <a href="http://www.skytrexmodelrailways.com">www.skytrexmodelrailways.com</a></p> <p>Free subscription to newsletters! Details on website</p>	<p>OO gauge redn and white metal kits</p>  <p>OO gauge modular building systems. Picture shows 4/041 north-light warehouse kit.</p>
--	--	--

Welcome to:

# SLATER'S PLASTIKARD

# STAFFORD MODEL RAILWAY EXHIBITION

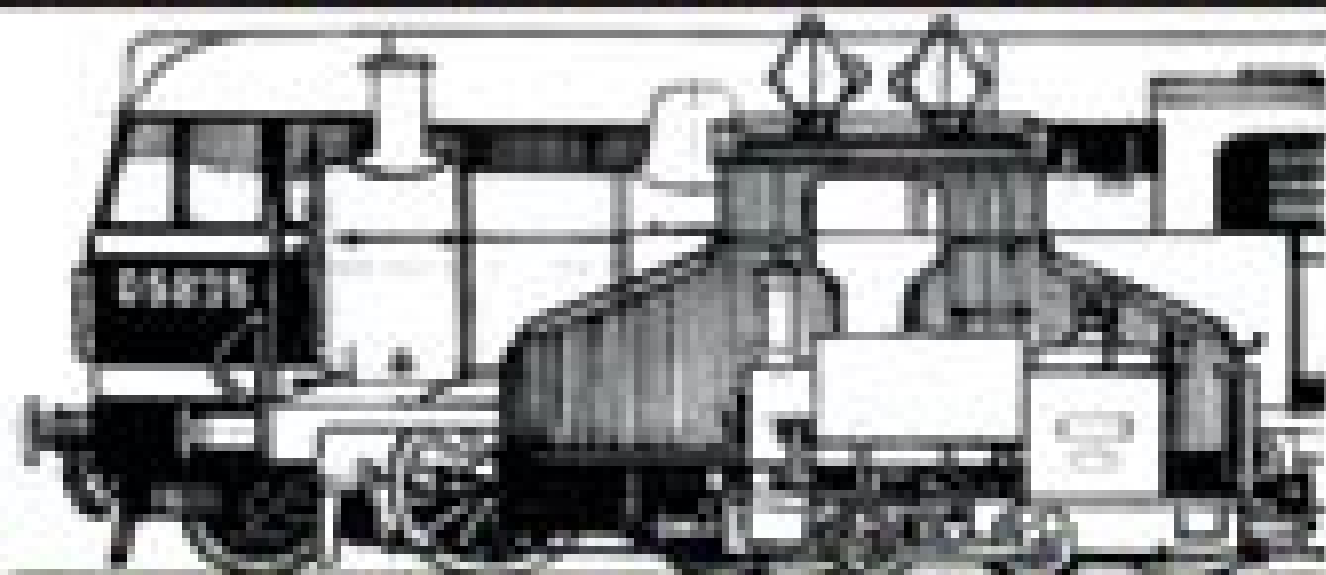

## Join us in 2020

**Saturday 1<sup>st</sup> Feb**  
(10am to 5pm)

**Sunday 2<sup>nd</sup> Feb**  
(10am to 4.30pm)

### Stafford County Showground

ST18 0DD - Situated on the A518, 3 miles East of Stafford Town Centre

**Adults £10 Admission**

*includes show guide while stocks last.*

*No Charge for accompanied Children under 16*

*See our featured area of 3mm scale layouts,  
Upwards of 35 layouts already booked  
in all the major scales.*

*-see our website for full listings-*

1957

**FREE bus from railway station**

[www.staffordrailwaycircle.org.uk/exhibition](http://www.staffordrailwaycircle.org.uk/exhibition)

1957

# The Midland Region in the 1970s and 1980s

Author: Andy Gibbs

Price Special Price: £13.49

ISBN 9781445681870

Size 234 x 165 mm

Binding Paperback

Illustrations 180

Published by Amberley Publishing

Review by M. D. Hooson

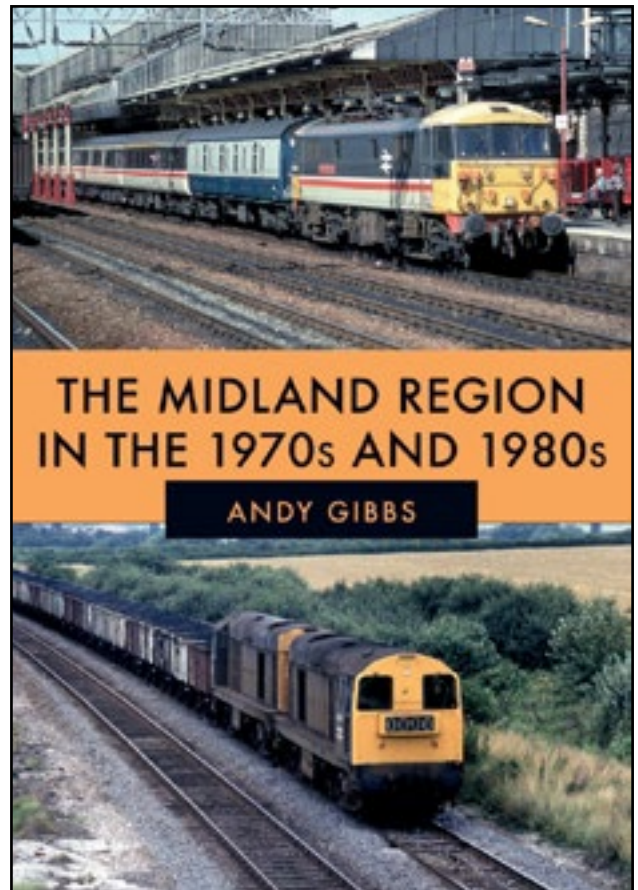

The haste with which the railways of Britain were unceremoniously dismantled would have left us all the poorer were it not for those who took their cameras and recorded an important part of our heritage. The record of their efforts in books such as Andy Gibbs' 'the Midland Region in the 1970s and 1980s' helps keep alive how important the railways were (and indeed are) to Britain. The concept of the permanent way suffered under the ephemeral nature of government and one can only bemoan the fact that modern photographic equipment was not available much sooner.

One can already see the disintegration of railway scenes under the guise of 'nationalisation' in several of the book's collection of photographic memories. Motive power over the two decades continued to soldier on leaving a legacy of pride and individuality. Names such as Ballymoss, Patriot, The Royal British Legion, Bishop Eric Treacy, Cock o' the North, Carabinier and Albion among others punctuate the pages of the book bringing back memories of journeys made and scenes seen. These were names that gave a unique sense of individuality which for most railway enthusiasts would undoubtedly evoke affection.

This book was a journey back in time to when long past journeys were made through Woodhead, Stalybridge, Manchester Victoria (there is even a view of the freight accounts offices at Hunts Bank where the writer's father spent much of his working life) and a view of 'The European' loco hauled train from Manchester to Harwich Parkston Quay which took roughly six hours. Sadly that journey is now done by a short sprinter train and constant shuffling about in composite seats.

London and North Wales evoke memories of holidays to Ireland, day trips to Chester and Llandudno while Banbury, Birmingham and Nottingham are not neglected by the author and he has added personal glimpses and informative observations to the pictures.

Andy Gibbs has put together a collection of colour and black and white photographs which cover a rich diversity of motive power – some in pristine condition, others not so. What he has included, however, paints a good reflection of the railway scene throughout the whole of Britain. Every schoolboy enthusiast would have had his favourite and so too the readers of this book. There is a choice of Peaks, Class 40s, DMUs, Class 20s and 25s and various electric locos and even APT370001 to look at and reminisce over.

This is not a book for merely glancing through but one requiring several visits.

*The Midlands has always offered a range of interesting locales for the rail enthusiast - Nottingham, Guide Bridge, Birmingham New Street and, of course, Crewe. As well as the usual range of passenger traffic, the region has a rich history of interesting workings - long, slow freights, merry-go-round coal trains and colourful Freightliner services - especially in the 1970s and 1980s, when Andy Gibbs explored the region with a camera and a desire to record this interesting part of the British rail scene.*

*Starting at Marylebone and heading north to Leamington Spa before coming back to London for the West London line and Kensington Olympia, Andy Gibbs offers a nostalgic portrait of the Midland Region when loose-coupled freights still lingered on and Peaks ruled the roost on Cross-Country*



services with a range of evocative and previously unpublished photographs. (Amberley Publishing)



Railway Films  
Collection



A Busy Day At:  
Bristol Temple Meads  
& Bristol Parkway  
Filmed in: 2003

[www.railwayfilms.co.uk](http://www.railwayfilms.co.uk)

Railway Films  
Collection



A Busy Day At:  
Worksop & Retford  
Filmed in: 1997

[www.railwayfilms.co.uk](http://www.railwayfilms.co.uk)

Railway Films  
Collection



The Ravensglass &  
Eskdale Railway  
Filmed in: 2005

[www.railwayfilms.co.uk](http://www.railwayfilms.co.uk)

Railway Films  
Collection



Newport  
in  
South East Wales  
Filmed in: 1999, 2003 & 2009

[www.railwayfilms.co.uk](http://www.railwayfilms.co.uk)

Railway Films  
Collection



A Busy Day At:  
Barnetby &  
Melton Ross  
Filmed in: 2014

[www.railwayfilms.co.uk](http://www.railwayfilms.co.uk)

## The Railway Films Collection

Representing Britain's railways since 1980 and continuing up to 2015/16 when Dave Long retired from filming & Online Models Ltd took over the RailwayFilms brand

[www.railwayfilms.co.uk](http://www.railwayfilms.co.uk)

Railway Films  
Collection



Barnetby, Melton Ross &  
Ulceby Junction  
Filmed in: 2004, 2010 & 2014

[www.railwayfilms.co.uk](http://www.railwayfilms.co.uk)

# Chew Magna - Part 3

By Terry Rowe

## The Station

The Chew Magna station building is based on the GWR Maiden Newton station.



Work is quite advanced on the main building. The buildings walls have been cut and assembled (below and opposite, top) and the covering of the walls has started. All the edging and corner stones are in place.





The flint stone covering is being prepared. by using printed flintstone onto a textured wallpaper giving it the look of real stone (below and p36 top)





The window frames are being cut and fitted and it is planned add an interior to the building at a later stage.

We are planning to adapt a L-Cut foot bridge to represent the actual foot bridge that was part of the Maiden Newton Station.

We are also modelling the train shed on the bay platform. Both of these are part of the next phase in the building of the station. Once this is done the buildings on the 2<sup>nd</sup> platform will be constructed in a similar way. The two platforms will also be upgraded to complement the buildings.

The GWR Foot Bridge by L-Cut Creative.

B 70-22 O gauge GWR style platform footbridge

<http://lcut.co.uk/index.php?product=B%2070-22&title=B%2070-22>



*The station building in position on the platform*



# Hopefield Branch - part 3

By the English Wildebeest

De Hoop Veld Station Buildings



De Hoop Veld is what my version of Hopefield is going to be called. The 1/43 scale layout (O Scale Narrow Gauge) will be on three 4-foot by two 2-foot boards, with 4-foot fiddle yards at each end.

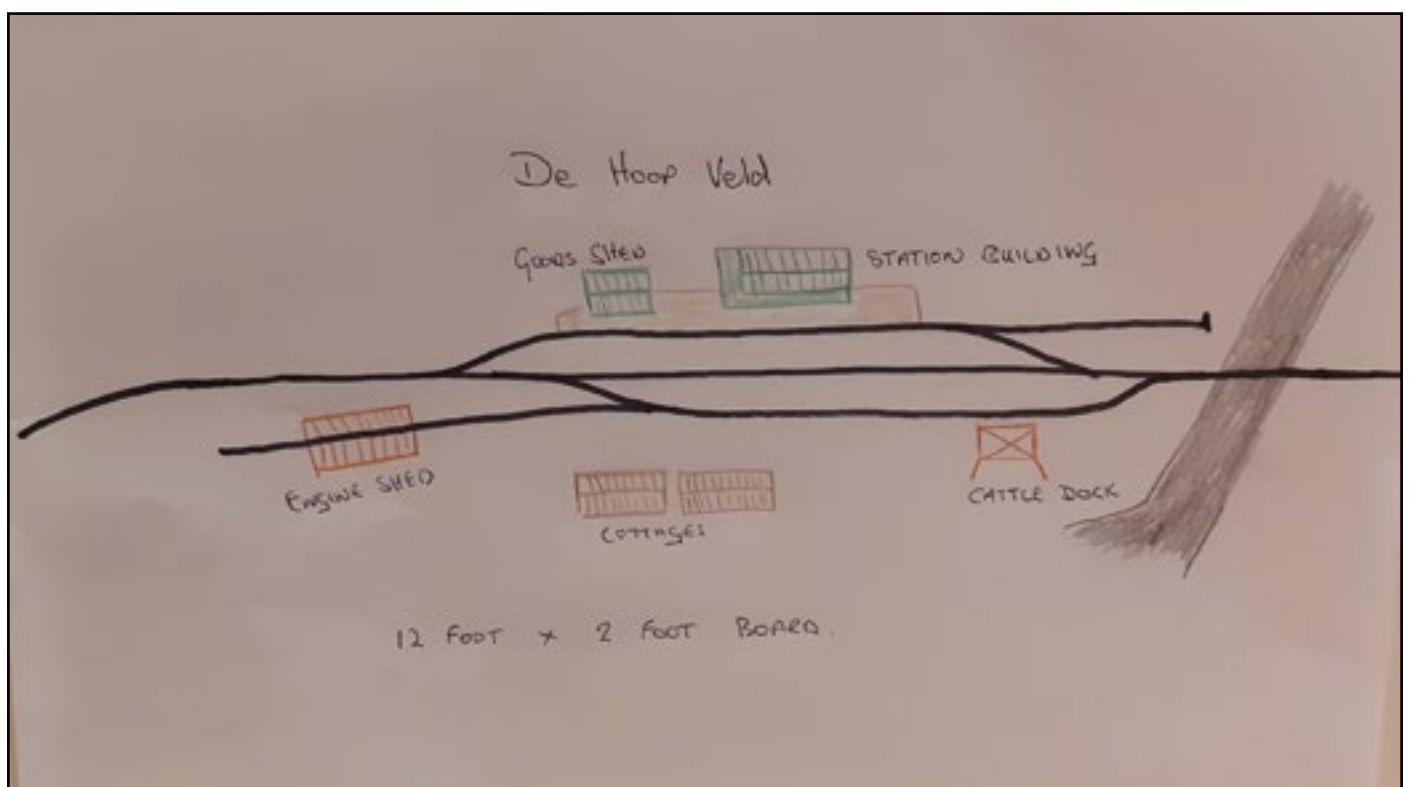

See my sketch of the proposed layout (opposite bottom) along with Sydney Moir's drawing of the Hoopfield Station track plan in 1901 (below)..

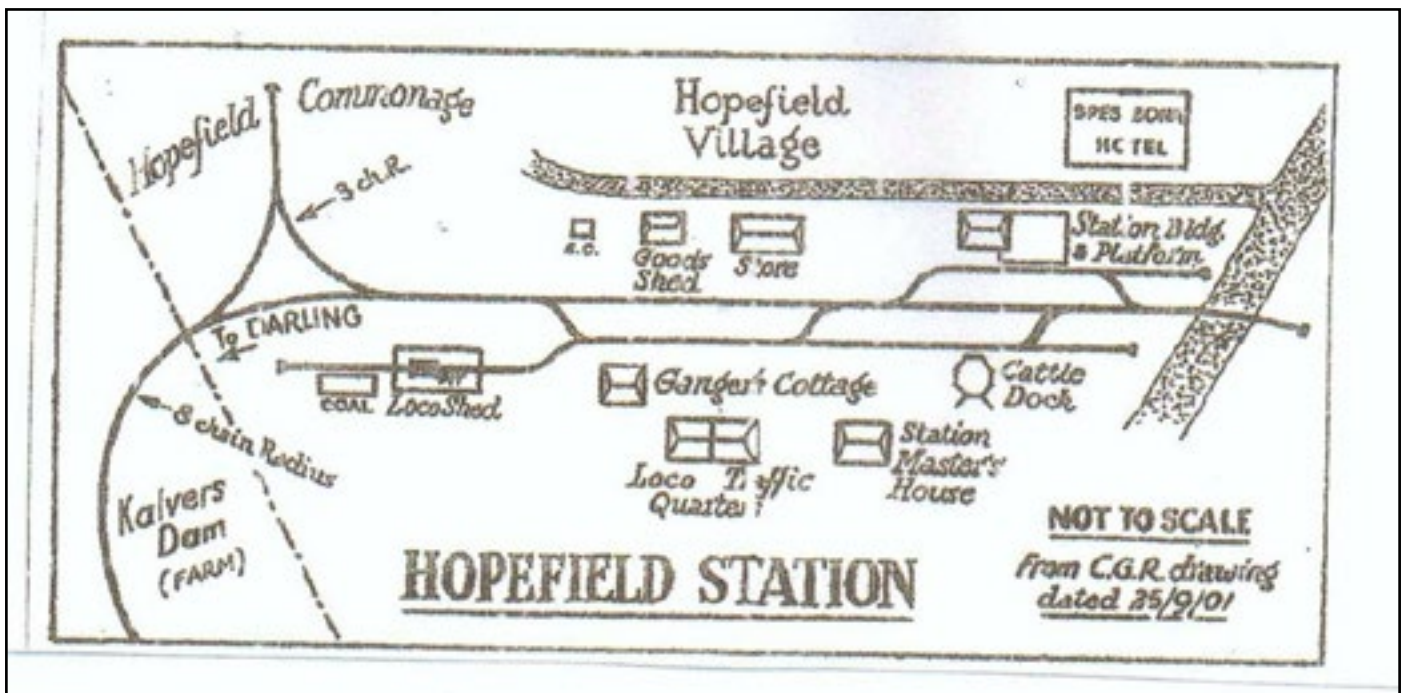

The project started some 8 years ago which included a visit to the Hopefield station in 2012. The original Cape Government Railway corrugated iron buildings amazingly still survive and models are a representation of those original buildings.



*Station building before painting*

I have used a mixture of plastic card and recycled pie dish foil for the corrugated iron. The corrugated iron was sourced on eBay under 'O' Scale 1/48 Corrugated Iron Sheets by Inside Track Models'. The doors and windows are resin cast.



*Station building model above and below the station in 2012*







*Small goods shed model above and below in 2012*



Although the line was only two-foot gauge from 1901 till 1926 when it was re-gauged to 3'6", Cape Gauge, as it is today. In my world this did not happen, and it remained a two-foot gauge line. My layout will be set in the 1950's, although this could change as I like the end of the CGR to the change over to South African Railways period, 1910.





# Winelands Light Railway - One Man's Railway

## The Introduction



The Winelands Light Railway is the culmination of a dream that started over 5 years ago. Andries Keyser is the man that took that dream and turned it into reality. He has built an impressive 7 ¼ “gauge miniature railway over a 5.7 Hector site situated near to where the ‘Old Paarl Road’ R101 meets the R304 just outside Stellenbosch in the Western Cape, South Africa. The railway represents a one third scale of the two-foot gauge railways that adorned South Africa.

The railway has live steam and electric locos that pull passenger wagons and coach around a full circuit of the 5.7 Hector over bridges crossing a lake, through a tunnel and between trees. The railway is open from 14<sup>th</sup> December 2019. Over the next few issues of this magazine we will tell you more about the owner and his railway.

<https://www.facebook.com/Winerail>



Address: 1941 R304, Stellenbosch, 7605, South Africa  
Phone: +27 62 206 1906



# Freight in the Peak District

Author: Paul Harrison

Price Special Price: £13.49

ISBN 9781445687728

Size 234 x 165 mm

Binding Paperback

Illustrations 180

Published by Amberley Publishing

Review by M. D. Hooson

It may be all too often easy to forget that the development of railways grew out of freight rather than the novelty of passenger services. The transport of bulk materials such as coal, slate, ores, cotton, potash and oil has always lent itself to carriage by rail. Sadly the demise of coal and other commodities has produced large reductions in the rail network across the UK. . Therefore Paul Harrison's book; 'Freight in the Peak District' is a pertinent reminder of the essential role railways play in the economy of the UK. Road transport has a place but 'common sensically' cannot usurp the ability of trains snaking through the British coun-

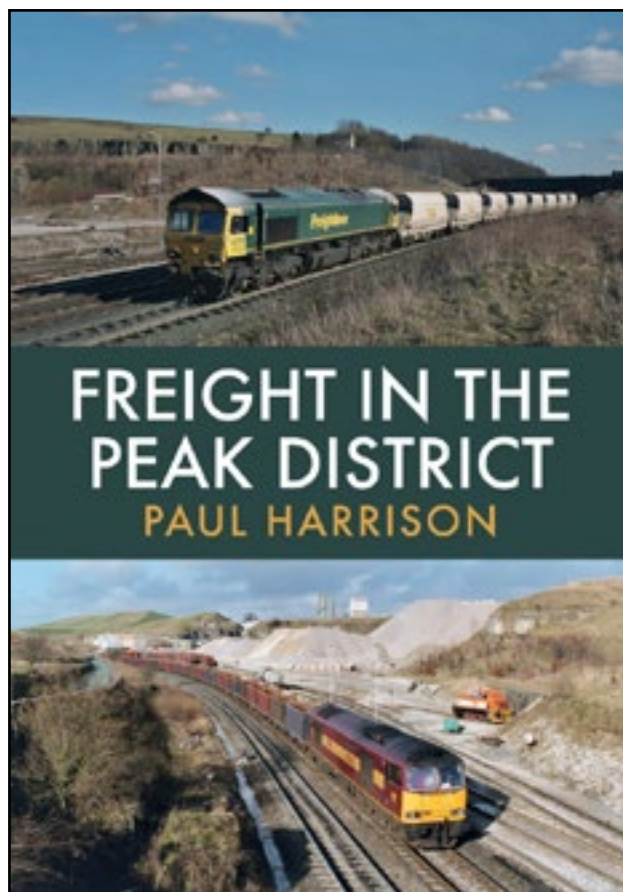

tryside hauling large numbers of wagons and hoppers. Notwithstanding this, the effect of a rail route on that countryside and any level of pollution is incomparable to that of any motorway. Recently taken photographs in the book would support this view.

The peace and tranquility of places such as the Hope Valley, Chinley, New Mills and Peak Forest are broken, perhaps momentarily and the railway is then largely invisible. Even the sidings photographed show a high degree of organization with minimal visible environmental damage.

Diesel traction provides the motive power in the 180 photographs comprising the book. Class 60s, 66s and 37s abound while space has been left for a couple of Brush locomotives, one or two Class 20s and the odd Class 47. Acknowledgement has been made to the Peak District's wintry conditions and a snow plough stays on stand-by in case global warming fails to materialize.

For those intrepid enthusiasts who want to see areas covered in this book Paul Harrison provides a map by way of guide.

*The Peak District area of England has yielded limestone products since around the time of the Romans and by 1794 the Peak Forest Tramway arrived to help transport products further afield. By the time the Midland Railway arrived in the Buxton area in the 1860s, limestone and stone traffic*

was booming by rail. Even now large tonnages of raw limestone, aggregates and cement are dispatched all over the UK.

This book illustrates some of these traffic flows, both past and present, and how they have changed locomotives and wagons. Some of these traffic flows are long-standing ones such as the Tunstead to Northwich, whereas others are more recent and short-term spot hire traffic. Privatisation in the mid-1990s saw EWS dominate the main flows but now DB Cargo, Freightliner Heavy Haul and GBRf all vie for lucrative flows from the four main rail-served quarries. (Amberley Publishing)

---



**Fine Kits  
of  
Buildings  
&  
Detailing**

**SevernModels.com**



# Ticket Office at Strathcarron Station

## Luxury self-catering accommodation in an historic building

Fully equipped kitchen/diner with original railway features, cosy sitting room, one double & one twin bedroom, wet room & en-suite shower room, oil fired central heating, wi-fi, washer/dryer. Fully disabled accessible

Sleeps a maximum of four. Minimum stay two nights.



For further information or to book visit  
[www.strathcarronstation.co.uk](http://www.strathcarronstation.co.uk)



[www.SMARTMODELS.co.uk](http://www.SMARTMODELS.co.uk)

**Download and Print Building Kits**



# Second Generation DMUs

Author: John Jackson

Price Special Price: £13.49

ISBN 9781445675961

Size 234 x 165 mm

Binding Paperback

Illustrations 180

Published by Amberley Publishing

Review by M. D. Hooson

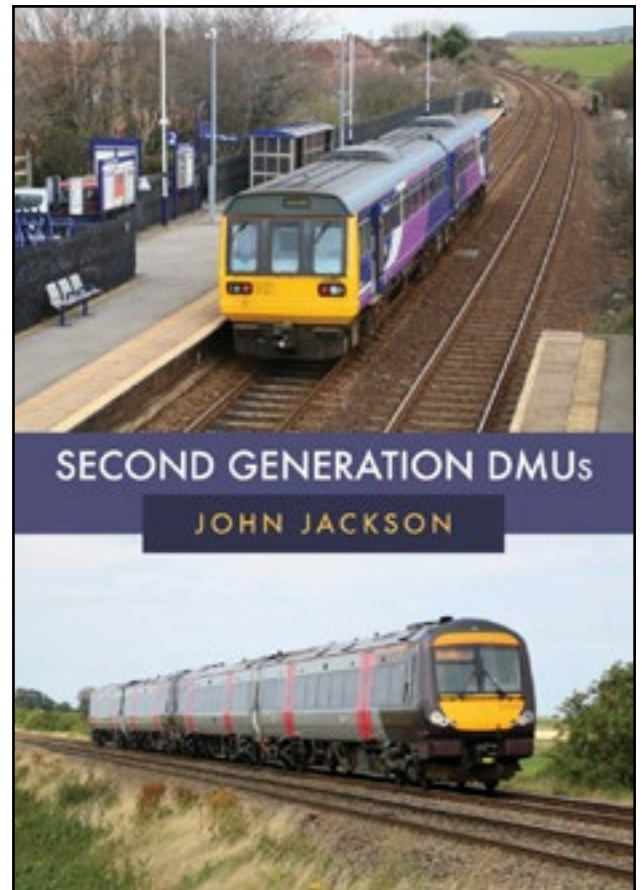

Given that the arrival of DMUs post 1968 was not a unanimously welcome innovations, especially in the case of some designs, noise and levels of comfort, this book goes a long way in redressing the balance of opinion. As with steam engines, even the ugliest came to be regarded with some affection. Despite rough, rocket-sounding engines being revved up inside stations, looking back, one might be hard pressed not to have a little nostalgia.

John Jackson's 'Second Generation DMUs' portrays fleets of modernized units in a variety of liveries. With

but a single loco in sight, the reader is wooed by neat, rounded profiles of Class 165s, 170s, 171s, 180s and their variants. All seem to be smaller reflections of larger trains such as Class 222s. All units have been photographed in service: Pacers, Sprinters, HSTs and even 'Experiments'. Complementing the traction are the many locations throughout Britain which are featured making this book of real interest to the rail enthusiast – even anyone who may have experienced the 'bus-style' seats and the rocking motion of first generation units in travel. In this respect, perhaps, the book dispels many negative memories of the first generation DMUs. This book is worthy of any enthusiast's bookcase.

*It is now more than thirty years since two words synonymous with Diesel Multiple Units became part of railway parlance – 'Pacers' and 'Sprinters'.*

*The Class 142 Pacers were introduced in the mid-1980s and, despite almost continuous criticism as to their lack of comfort, these 'nodding donkeys' remain in revenue-earning service. From these beginnings in the 1980s our rail network has seen a total of twenty or so classes of Second Generation DMUs enter service. Indeed, they are the mainstay of secondary passenger services on non-electrified lines right across the network. This book takes a closer look at these units in action with each class on display. From examples of ScotRail Class 158s and 170s on*

*services out of Inverness to the Great Western Railway's Class 150s and 153s working services in Devon and Cornwall, this book is also a whistle-stop tour of non-electrified lines across the UK. These lines have survived into the twenty-first century and the second generation DMU has played an important part in this.*

---



**Double 0 Gauge Association.**  
**Run by 00 modellers for 00 modellers.**  
Get more from YOUR hobby with DOGA help and advice.

Quarterly Journal, Private website, Facebook page.  
Visit [doubleogauge.com](http://doubleogauge.com) to download application form.  
OR SAE to: Membership Sec, 219 Gipsy Road Welling DA16 1HZ.

Photograph copyright: Trevor Jones



## Our Narrow Gauge Products

### 4mm NER/LNER 20TON HOPPER WAGON

We have now re-launched our  
4mm Scale NER/LNER 20 TON HOPPER WAGON kit.

#### Features

- A finely detailed Plastic Wagon Kit.
- Waterslide transfers.

This kit does require the wheel sets.

Priced at £8.15 Inc VAT.



### 7mm Lynton & Barnstaple

We are now test building our Lynton & Barnstaple  
Railway coach No 7 in 7mm scale. This model features  
a detailed interior, and is assembled into two main units. The  
two parts sliding together, trapping the glazing, and thus  
making painting easier.



### 7mm Lynton & Barnstaple Wagon Kits

LYNTON & BARNSTAPLE WAGON KITS ARE NOW AVAILABLE.



N7W01  
LYNTON & BARNSTAPLE  
RAILWAY EARLY 4 TON  
OPEN WAGON £21.00 inc vat



N7W02  
LYNTON & BARNSTAPLE  
RAILWAY LATE 4 TON OPEN  
WAGON £21.00 inc vat



N7W03  
LYNTON & BARNSTAPLE  
RAILWAY 4 TON CLOSED  
VAN £22.00 inc vat

PLEASE STATE WHICH WHEELS YOU REQUIRE 16.5 OR 14MM GAUGE.

We operate a World Wide mail order service, usually dispatched on the same working day.  
Order via our web site, or by phone or letter.

Visit Our Website. [www.slatersplastikard.com](http://www.slatersplastikard.com)

# Midlands Model Engineering Exhibition 2019 Review



The annual Midlands Model Engineering Exhibition proved a great success yet again this year providing entertainment for everyone!

Over 35 club stands were present displaying over 1000 models and bringing model engineering to life with a variety of them offering demonstrations throughout the weekend displaying the vast range of possibilities that engineering can offer. As if there wasn't enough to entice you into the wonderful world of model engineering on their stands then the large array of competition and display entries offered an impressive fleet of stunning representations that were impossible to resist.

The magnificent Fosse Way Steamers, the Gas Turbine Builders Association and the popular 5" gauge passenger carrying locomotive were all present and in full force outside, braving the weather to offer visitors active displays of their models.

The exhibition also gave engineering enthusiasts and

the newly inspired the ability to take something home with them. Modellers were not only able to stock up from over 40 specialist suppliers who attended the exhibition, but also gain some valuable knowledge from the expert lecturers and workshop demonstrations offered throughout.

Planning is already underway for next year's exhibition which will take from Thursday 15<sup>th</sup> October to Sunday 18<sup>th</sup> October 2020 at the Warwickshire Event Centre.

If you don't think you can wait that long, and we know we can't, then why not come along to our sister exhibition; the London Model Engineering Exhibition! To book advance tickets or for further information please see [www.londonmodelengineering.co.uk](http://www.londonmodelengineering.co.uk).

# COMPETITION CLASS WINNERS

CLASS 1 : Locomotives up to and including gauge 1

## **1<sup>st</sup> Prize**

Giancarlo Mastrini      Italian Railways Consolidation  
Locomotive

## **Commended**

David Viewing              L&NWR 4-2-0 Locomotive  
No. 153 (built 1847)

CLASS 2 : Locomotives – 2½” an 3½” gauges

## **Very Highly Commended**

Dave Lee                      ‘Locomotive ‘Mona’ - LBSC  
Design

CLASS 3 : Locomotives – 5” and 7¼ ” gauges and above

## **Very Highly Commended**

Alasdair Milne              GNSR Locomotive No.49  
Gordon Highlander



CLASS 4 : Rolling stock etc any gauge

**Highly Commended**

Dave Lee

Contractors Open Coal Wagon

CLASS 5 : Stationary engines

**1<sup>st</sup> Prize**

Royce Alfred Limb

Tandem Double Acting  
Stationary Engine

**2<sup>nd</sup> Prize**

David Rhodes

Duplex Reversing Stationary  
Engine

**3<sup>rd</sup> Prize**

Peter Wardle

4 Cylinder Vacuum or  
'Flame Licker' Engine

**Very Highly Commended**

David Rhodes

Twin Cylinder 'A' Frame  
Stationary Engine

**Very Highly Commended**

John Wing

Trojan Stationary  
Steam Engine

# CLASS 6 : Steam road vehicles

## 1<sup>st</sup> Prize

John Dickinson

Foden C Type

Wagon with van body

## 2<sup>nd</sup> Prize

Peter Lee

Savage 'Little Samson'  
Steam Tractor

**New Modellers Shop**

Providing friendly advice for beginners

<p><b>HORNBY</b></p> <p>We stock everything you need to complete your Hornby Trakmat Layout, turning your train set into a fully functional model railway.</p> <p>Track Packs and Building Packs</p>	<p><b>NOCH</b></p> <p>Specialist in Model Landscaping</p> <p>100+ Themed Figures Packs in Stock</p> <p>Trees Available in all Size / Colour / Shape</p>	<p><b>SUPERQUICK</b></p> <p>All of the Superquick range of model card kits for OO / H0 model railways, stocked.</p> <p><b>OXFORD</b></p> <p>Vehicles are a must have for any model railway &amp; we have 100's to choose from.</p> <p>We sell a comprehensive range of models.</p>	<p><b>HORNBY</b></p> <p>SPARRS</p> <p>We have in stock a wide range of common spares for same day dispatch.</p> <p><b>ART Printers</b></p> <p>The popular self-adhesive backscenes are available from us in a variety of themes and scales to suit your layout. (OO / N)</p>
--	---	--	--

Website: [www.newmodellersshop.co.uk](http://www.newmodellersshop.co.uk) Telephone: 01733 704502 Email: [info@newmodellersshop.co.uk](mailto:info@newmodellersshop.co.uk)



Available To Order Today At:  
[www.onlinemodelsltd.co.uk](http://www.onlinemodelsltd.co.uk)

Code: Product Description:

- BN01L Left Platform Offset Starter (R/G 2 aspect)
- BN01R Right Platform Offset Starter (R/G 2 aspect)
- BN02 Platform Starter (R/G 2 aspect)
- BN03L Left Offset Platform Starter (R/Y/G 3 aspect)
- BN03R Right Offset Platform Starter (R/Y/G 3 aspect)
- BN04T Island Platform Starter Twin (R/G 2 aspect)
- BN28 Standard (R/G 2 aspect)
- BNH2 Signal Head (R/G 2 aspect)
- BNH3 Signal Head (R/Y/G 3 aspect)
- BN31L Left Standard Offset (R/Y/G 3 aspect)
- BN31R Right Standard Offset (R/Y/G 3 aspect)
- BN32 Platform Starter (R/Y/G 3 aspect)
- BN36T Island Platform Starter Twin (R/Y/G 3 aspect)
- BN38 Standard (R/Y/G 3 aspect)
- BN41L Left Standard Offset (R/G 2 aspect)
- BN41R Right Standard Offset (R/G 2 aspect)
- BN62J T Junction Twin (R/G 2 aspect)
- BN77 Dwarf Ground (R/G 2 aspect)



Available To Order Today At:  
[www.onlinemodelsltd.co.uk](http://www.onlinemodelsltd.co.uk)

MODEL TRAINS & ACCESSORIES  
00, N & 0 Gauge Specialists

# RAILWAY CONDUCTOR



Die Cast | Radio Controlled | Toys

# Hill's Tramroad Blaenavon World Heritage Site

Author: Chris Barber

Price: £14.99

ISBN No.: ISBN 978 1 4456  
9400 9

Size: 234 x 165 mm

Binding: Paperback

Illustrations: 100

Published by Amberley Publishing

Review by Dale A. Heys

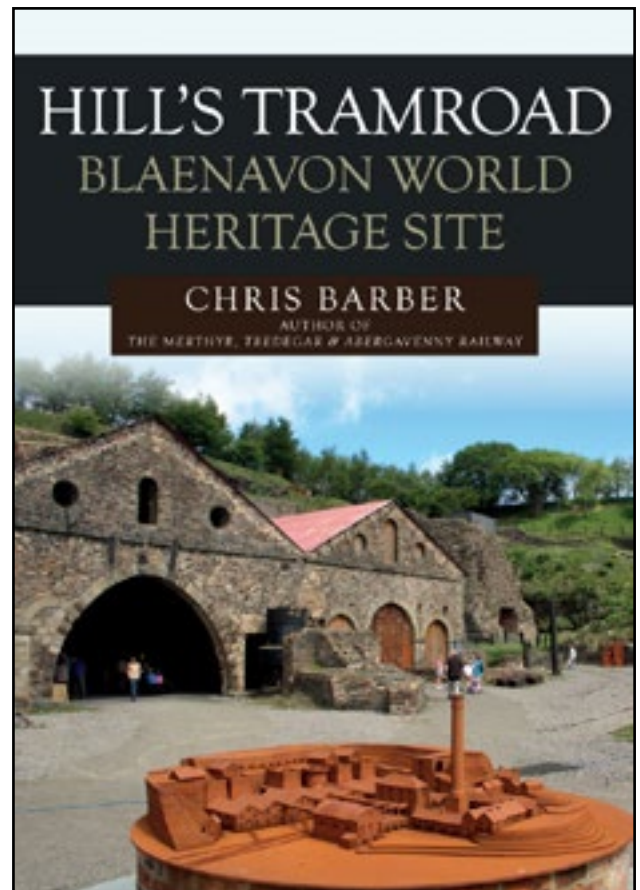

This book covers the history and story of the “Hill’s Tramroad” which linked Blaenavon Ironworks and the Llanfoist Wharf on the Brecknock & Abergavenny Canal.

There are a number of rarely used or seen illustrations. It was one of the earliest transport routes having been built in 1817 and Chris Barber takes you on a fascinating journey through its history.

The early part of the book covers the history of the

railroad, Blaenavon Town and the Ironworks and the later part takes the reader on a walking tour along the remains of the tramway between Blaenavon and Llanfoist detailing all the high points along the route of the tramway.

The book makes a very interesting read and gives a fascinating insight into one of the earliest transport routes in Wales.

I personally found this book very interesting to read and would be of interest to any body interested in early transport and industrial history.

It is interesting to note that the area around Blaenavon has been named a UNESCO world heritage site in recognition of its place in industrial history.

*Between 1760 and 1840 a chains of ironworks established along a narrow strip of hill country stretching for 20 miles at the 'Heads of the Valleys' in South Wales took advantage of the rich deposits of ironstone, limestone and coal that were essential raw materials for the iron making process. At Blaenavon can be found the best-preserved multi-furnace complex of its type and period in the world. The surrounding landscape is extraordinary; everywhere you look, there is fascinating evidence of human endeavour over the last 200 years.*

*Linking the ironworks to the sources of iron ore, coal and limestone is an intriguing network of primitive railways known as tramroads – they even include the longest tunnel in the world, constructed for horse-drawn operation.*

*“Hills Tramroad” tells the remarkable story of the magnificent feat of engineering.*

*(Amberley Publishing)*

---



If this appeals to you, join our Facebook group - [5.5mm Scale Modular Group](#) or come and see us and our modular layout at an exhibition.

Email [steve.cuisine@gmail.com](mailto:steve.cuisine@gmail.com) for details of our forthcoming exhibitions

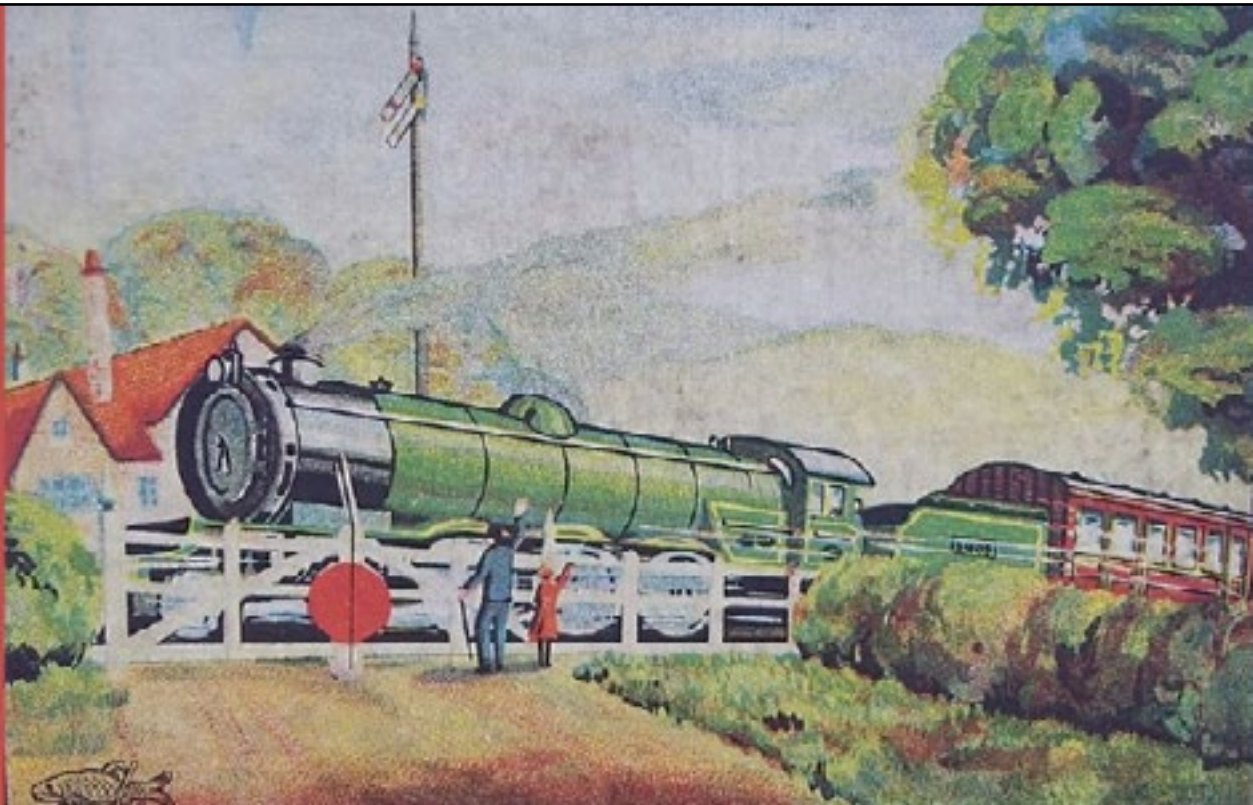



### Tenement Building

Available in 3 different finishes  
Modular design allows you to add as many floors as you want.

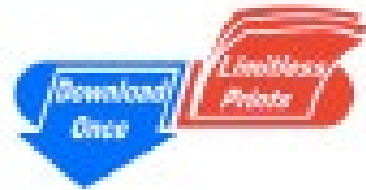

**Only £6.99**

Available in N & OO scale

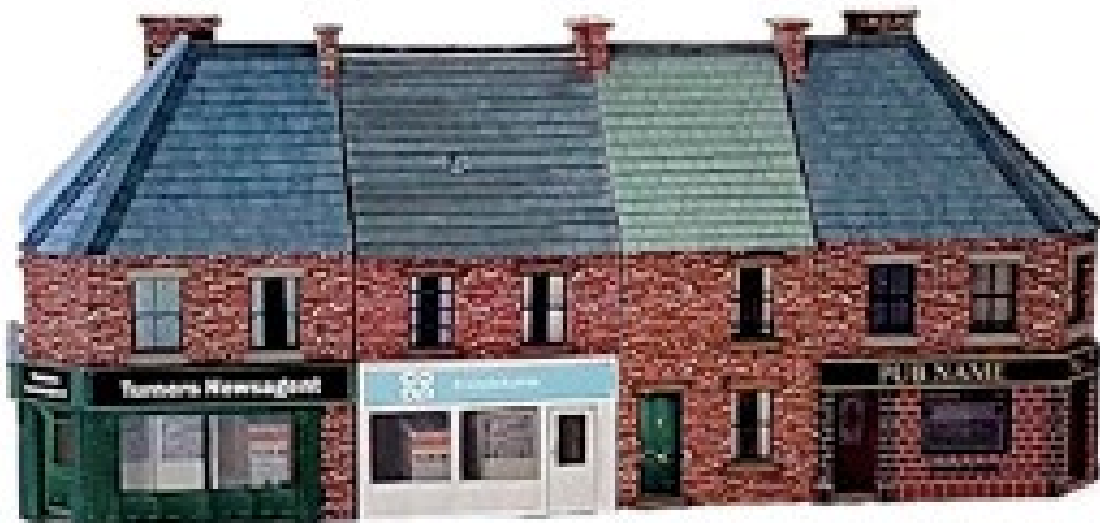

**Small  
Corner  
Shop £3.99**

**Small  
Terraced  
Shop £3.99**

**Small  
Terraced  
House  
£2.99**

**Small  
Corner  
Pub £3.99**

Available in N, OO & O Scale

**WWW.SMARTMODELS.CO.UK**

Download and Print Building Kits & Laser Cutting Service



## **London Model Engineering Exhibition 2020** **ALEXANDRA PALACE, LONDON**

**FRIDAY 17<sup>TH</sup> – SUNDAY 19<sup>TH</sup> JANUARY 2020**

The South's Largest Model Engineering & Modelling Exhibition returns in January from the 17<sup>th</sup> – 19<sup>th</sup> 2020. This exhibition is regarded as one of the leading model shows in the UK and attracts over 14,000 visitors annually.

Come along and see the full spectrum of modelling from traditional model engineering, steam locomotives and traction engines through to the more modern gadgets including trucks, boats, aeroplanes, helicopters and robots.

Visitors can travel between the show's different zones, trying the activities and watching fascinating and technical demonstrations. Over 50 clubs and societies will be present displaying their members work and competing to win the prestigious Society Shield. In total, nearly 2,000 models will be on display.



Organisers expect to welcome the return of the British Model Flying Association, Tamiya Trucking Group, Brickish, The Imagineering Foundation and the Polly Owners Group who provide passenger rides behind the 5" gauge steam locomotives within the Great Hall.

All of the leading suppliers will also be present showcasing new products and special promotions and giving hobbyists an excellent opportunity to see and compare products under one roof. You will be able to purchase virtually anything you need for your next model or project or to get you started in a hobby.

If you are an active model engineer this is a key event in the calendar to meet other hobbyists and see the leading suppliers. This is a great day out for all the family, one the children will love with all the working models. If you are interested in modelling yourself or want to rekindle your childhood memories, you will find something amongst the many diverse types of modelling on display to admire. If you are not already a modeller hopefully the exhibition will fire your imagination to build something yourself and enjoy one of these satisfying hobbies.

# **The South's Major Showcase of Modelling ..... Not To Be Missed!**

## **Dates & Times:**

Friday 17<sup>th</sup> – Sunday 19<sup>h</sup> January 2020

Open 10am – 5pm Friday and Saturday and 10am -  
4.30pm Sunday.

Last entry is 4.00pm Friday and Saturday and 3.00pm  
Sunday.

Model Active Zone closes at 3.30pm on the Sunday  
Cash Box opens at 9.00am each morning before the  
event opens at 10.00am



## Admission:

Ticket	On Line Tickets  Discounted tickets via website	Full Price Tickets  On the Door
Adult	£11.50	£12.50
Senior Citizen/Student	£11.00	£12.00
Child (5-14)	£4.00	£4.50

To book tickets go to [www.londonmodelengineering.co.uk](http://www.londonmodelengineering.co.uk).

**Discounted tickets available until midnight Tuesday 14<sup>th</sup> January 2020.**

If you would like to order by phone please call SEE Tickets 0115 8960154.

Meridienne Exhibition cannot process any telephone orders for tickets.

If you have general enquiries regarding the exhibition other than to book tickets please call 01926 614101.

For groups of ten or more discounts are also available. Please quote GRPI0.

# Railway Refreshments: The Final Whistle, Southwell

By Cath Locke

The Final Whistle is situated on what was a branch line from Rolleston (on the Midland Railway's Nottingham-Lincoln line) to Southwell but is now a popular walking route; the Southwell Trail.





Originally opened in 1847 and served by weekly horse-drawn passenger services (to 1853) steam eventually arrived in 1860 and the line was extended to Mansfield and the wooden station rebuilt in stone.







Passenger services to Mansfield ceased in 1929 but the tank engine and single carriage Rolleston to Southwell 'Paddy' (as it was known) continued running until 1959.

The line continued to move coal and the odd excursion train until 1965 and the track was finally taken up in 1969.

Although not in the old station building (which can be seen opposite the pub) the pub was refurbished by Everards in the style of a 1920s platform and named to recognise the end of the railway in Southwell. Full

of railway memorabilia the pub garden is set out as railway platform with wooden canopy and level crossing-style gates. The function room is called the 'Locomotion'.

Serving a good selection of real ales and food too I was only sorry my visit was mid afternoon and not really the time for either.



*This looks like the original stone built station building opposite the pub*

**GREAT EASTERN MODELS**





# THE UK Model Shop Directory



[WWW.UKMODELSHOPS.CO.UK](http://WWW.UKMODELSHOPS.CO.UK)

Providing the **LARGEST** Online resource  
for **British Railway Modellers and  
Enthusiasts.**

---

**Over 200,000 page hits per month**

---

**Model Shops A-Z** with  
Google Maps, Photographs, Customer  
Comments and Star Ratings

---

**Suppliers A-Z** fully indexed and  
cross-referenced by Scale and Category

---

**Clubs and Societies Directory**

---

A 12 Month **EXHIBITIONS CALENDAR** with  
Google Maps and INFUZER Technology for your PDA

---

**Model Rail Magazine Index**, all issues from #1

---

**Modelling References and Links**

---

With daily updates something new is always happening on

**THE UK Model Shop Directory**

[WWW.UKMODELSHOPS.CO.UK](http://WWW.UKMODELSHOPS.CO.UK)



# The 1896 Light Railways Act

Author: John Hannavy

Price Special Price: £11.24

ISBN 9781445693446

Size 234 x 165 mm

Binding Paperback

Illustrations 140

Published by Amberley Publishing

Review by Cath Locke

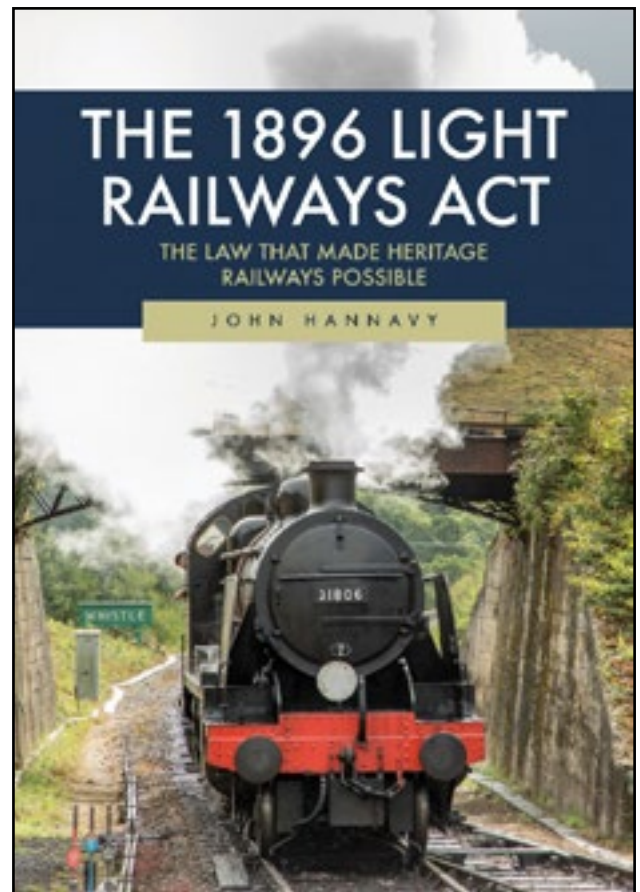

Not a photo book from Amberley this time (although it is filled with a wealth of images). This one is a fascinating look at the 1896 Light Railways Act; the Act that is credited with enabling the realization of many of today's heritage lines.

The nineteenth century saw a rash of railway building with many different railway companies simply building their own routes to and from key locations. Consequently there was no nationwide integrated strategy and many locations ended up as destinations for more than one line and multiple stations were built in a sin-

gle town or city, sometimes almost next door to each other.

Whilst some lines quickly ran into trouble, once completed because they were ill advised or uneconomic to run, others ran out of money before they even got started because of the effort (and cost) of gaining official approval. Another key factor in the economics of railway planning was the infrastructure needed to get track over hills and vales.

Whilst it can be argued that the sheer range of geology and topography in the United Kingdom pushed engineering development to new heights (quite literally, sometimes) and has given us structures we treasure today (such as the Glenfinnan Viaduct, the Conwy Bridge and Box Tunnel to name but a very few) the cost of such schemes was integral to the mathematics of the viability of new lines.

It was just as well that the bulk of Britain's railway network was complete by the end of the nineteenth century as money for such capital outlay was becoming scarcer and some investors from the previous half-century were even bankrupt as a result of schemes that were supposed to make them rich.

Although Victorian Parliamentary approval processes had scrutinized routes and proposed standards of construction and operation little attention had been paid

to funding issues as it was private money being invested.

With the main network complete by the 1880s many shorter routes although planned, remained uncompleted as investors shied away from the sheer cost of gaining approval and having to build lines that would only ever see light use to standards required of lines that saw high volumes of heavyweight traffic.

But with a booming Victorian economy and a yet under developed road network there remained a need to build feeder lines to move goods to key railheads. And against this recognized need was set the existence of a tramways, mineral lines and narrow-gauge railways all built to lower construction standards and yet, apparently safe, reliable and economically viable.

And so the 1896 Light Railways Act was born. It was intended to both streamline and reduce the cost of the approval process as well as allow more realistic standards of compliance for new railways (and thereby reducing build costs) albeit without compromising safety.

Much debate preceded the passing of the Act including proposals that 'light' railways should only be narrow gauge (thereby necessitating transshipment of goods at all railheads where the new lines met standard gauge lines) and (how radical was this?) the idea of combined

passenger and freight trains (allowing lines to be more cost effective).

Eventually the Light Railways Bill was laid before Parliament (with little definition of what actually constituted a light railway) and the Light Railways Act was passed on 14<sup>th</sup> August 1896.

Although vague on what a Light Railway was it brought much reduced approval costs with just three Light Railway Commissioners to consider each new proposal and to be pro-active in approving new lines.

The Act also significantly reduced requirements around track foundations and ballasting (thereby also reducing costs of maintenance crews required to constantly re-ballast), signaling (with just 'staff' or 'token' systems) and level crossing and station infrastructure reduced too.

Initially intended to lapse after 5 years the Act was extended in 1901 as the 5 year period, whilst allowing many lines to be approved, was not long enough to see them built and commissioned. But by the end of the First World War although over 300 light railway orders had been granted over three-quarters of them never made it to fruition. Despite the reduced approval and construction requirements funding remained elusive the passing of the Locomotives on Highways Act (that raised speed limits on roads to a heady 12 mph) in the

very same year as the Light Railways Act the shipment of goods by road was becoming more economically viable in the early 20<sup>th</sup> century.

Although railways could deliver goods (and people) from station to station, these were often still a distance away from the final destination and additional transport was needed to reach factories and homes. And as road transport could just as well move goods from door to door railways began to lose custom to economically viable road hauliers.

And so came attempts at modernising both the network and its operation and ultimately, of course, Messrs Marples and Beeching.

And here is where the Light Railways Act of 1896 enjoyed a new lease of life. Never repealed the Act had unintended, and very fortunate, consequences in breathing life into our many heritage lines today.

Although the idea of preserving actual locomotives had long been recognised (as evidenced at the various museums) the idea of preserving and operating a whole railway was unknown before the mid-twentieth century – but was enabled the 1896 Light Railways Act through the continuing availability of Light Railway Orders.

The Talylyn line in Wales became the world's first heritage line when its preservation society was born in

1951. Since then many, many more have followed. Some, like the Talylyn, potentially slightly easier than others being already narrow gauge and in private ownership but others standard gauge and requiring the purchase of the trackbed and sourcing and restoration of rolling stock.

Today's modern heritage railways that are enjoyed by many thousands of enthusiasts from all over the world are complex beasts subject to as stringent demands as their Victorian forebears in terms of health & safety legislation, operating regulations and economic planning. But the world would be much poorer without them.

This book is a fascinating look at the development of railways, why some foundered or never got going, the rise of road competition and the ultimate state the railways were in by the time Mr Beeching came along with his axe and finally the new life being breathed into history – all enabled by a piece of Victorian legislation that somehow outlived its original intent.

And at the back of the book there is also a very useful list (with contact details and brief descriptions) of standard gauge lines open in the UK today as a result of the Act.

A fabulous documentary accompanied by excellent pictures. I have thoroughly enjoyed reading and reviewing this one from Amberley!

*'In no other country in the world is there anything to match Britain's love affair with the steam train; nowhere else are there so many preserved railways keeping the magic of steam alive.' In 1896, the Light Railways Act was designed to speed up the official procedures for gaining approval to construct a railway line. Originally intended to lapse in 1901, it was extended instead, and somehow stayed on the statute books long after its use had ceased. In the 1960s, groups of steam railway enthusiasts recognised it as a possible means of gaining approval to reopen stretches of railway lines that had been closed by Dr Beeching, keeping the steam dream alive. More than half a century later, some of these restored lines have already celebrated their golden jubilees, and their popularity continues to grow. Thanks to the unintended consequence of that 1896 Act, each new generation since Beeching has had - and will continue to have - the opportunity to enjoy the magic of steam trains. Along with a wealth of evocative images, John Hannavy explores the fascinating story behind a Victorian law with a welcome and unexpected side effect - leading to today's popular heritage railway industry. (Amberley Publishing)*



# Model Railway



Image copyright © Chris Neward (Model Rail) and reproduced with permission.

**The Longfield Academy  
Main Road**

**Longfield, Kent DA3 7PH**

**Saturday & Sunday**

**25<sup>th</sup> January 2020**

**(10.00am to 5.00pm)**

**26<sup>th</sup> January 2020**

**(10.00am to 4.00pm)**

**Up to 35 Layouts  
Society Stands**

**Extensive Trade Support  
Hot & Cold Refreshments**

**Demonstrations  
Static Displays**

**Adults: £9.00**

**Accompanied Children (5-16): £1.00**

**Exhibition presented by**

**ERITH MODEL RAILWAY SOCIETY**

Flyers sponsored by



[www.erithmrs.ukmodelshops.co.uk](http://www.erithmrs.ukmodelshops.co.uk)

Follow EMRS on...



# Railcars

By Bob Hughes

I have something of a penchant for railbuses, railcars and freight motors. Some of these models are of rather ambiguous scale, so they can be used as small vehicles on my main (On30) layout or as larger vehicles on the 5.5mm scale modules.



## 5.5mm only



*The Dennis railbus was built specifically for 5.5mm scale, it's a pair of Lledo die cast buses mounted back to back on a Piko mechanism.*



*The Bedford K railbus is a Bachmann HO scale coach body adapted for 5.5mm scale and paired with a Lledo cab. This one runs on a Hornby chassis.*

*“Lizzie” is a freight motor made using an old Tri-ang wagon body with a die-cast Ford Model T from the Disney/Pixar Cars 1/55 scale range powered by a Bachmann Underground Ernie inspection car mechanism.*





*Railcar number 4 is an oddity. If it looks vaguely French that's because it is, it's a Dinky model of a French caravan with has two doors on each side, much more in keeping with a rail vehicle than a holiday hovel! Number 4 runs on a Hornby steam loco chassis but the wheels are almost completely hidden by the low slung body. Nominally 1/43 but it works well with 5.5mm scale.*

## **Either 5.5 or On30**

*Railbus 28 is a cheap Chinese die cast model of an American school bus, this was marketed as 1/50 scale but seems too small when used alongside my On30 trains so it is better suited on the modules. Number 28 runs on an Athearn HO diesel mechanism.*





*Railbus 35 is a Teamsterz coach body, beefed up using coffee stirrers to give it a heavier appearance, paired with the cab from a Bedford O lorry and powered using a Piko mechanism in the coach section.*



*Railcars 36 and 37 are a matching pair of Renault buses by Solido, one on an Athearn HO diesel chassis, the other on a pair of OO coach bogies. These were built for On30 scale and are pretty big if used on the modules though not excessive for rail rather than road carriages.*



## On30 only

On30 has been my modelling passion for the past ten years or so and has developed into a large home layout called the Ferrocarril Consolidado Pampa y Fernandez (FCPyF). Latin American railways make good use of road vehicles converted for rail and the FCPyF is no different.



*The un-numbered Trojan van is a Dinky die cast model powered by a Bachmann OO DMU chassis, it's not a particularly good runner though so it might get a permanently coupled trailer to provide additional electrical pick up.*



*Freight motor 9 is an amalgam of a Russian die cast truck cab with a Gnomy van body on a Dapol Terrier chassis. I very much doubt that there's anything vaguely like this in the real world but so what? I like it anyway!*

*Freight motor 20 is the cab from a failed (stripped gear) Bachmann rail truck now running with a scratch built boxcar body driven by a German railbus chassis.*





*21 “El Ganzo” (The Goose) was converted from a model of a Galloping Goose by Brian Mosby, it uses a Bachmann On30 boxcar in place of the original passenger carrying rear section. A lovely runner on level track but it doesn’t like the gradients on the upper line so it has limited route availability on the layout and is restricted to use between Grande and San Fernandez.*



*Railcar 22 should be recognisable as a Bachmann product but it too stripped the gears so the bus and its trailer have been united as a single railcar on another Athearn chassis.*



*25 is a very simple conversion, just a suitably sized die cast minibus mounted on a Model Power mechanism. It is used as an inspection vehicle and can be seen running on the FCPyF either solo or attached to the Jeep FC pick-up that has been mounted on rail wheels, this is an unpowered dummy.*



*27 is a model of a Maltese bus riding on a shortened Bachmann F7 mechanism. In common with most of the railcars its rear wheel arches have been “plated over”. In this case I used filler but it can be simpler, and more durable, using card or tinfoil sheet to do the job.*



*Railcars 30 and 305 are built from cheap kiddies' plastic toys. I have no idea what the prototype they're based on but their similarity would suggest there is something remotely like them running somewhere. 30 was converted by me and 305 is an eBay purchase, though I was unsatisfied with the (Lima) chassis it came with so both now run on Athearn mechanisms.*





*I have recently acquired two more railcar bodies, similar to 30 but matching the loading gauge of 305. These will be used to make 305 into a three car train (work in progress)*

I was asked to write this article by Peter Blackham and I suspect the reason why is my Bubblecar inspection vehicle, which he took an immediate shine to when I took it to the Narrow Gauge North 2019 Show!





*It's a die cast body stuck to a Bachmann Underground Ernie mechanism using Blutack. This is finescale modelling at its absolute nadir, unless you include the other FCPyF inspection car, a Disney-Pixar "Guido" (Fiat 500) mounted on a Bachmann gandy dancer mechanism.*



*Fiat, probably best to say no more about this one!*

## Big Steam, Narrow Steam and Shiny Nails Part 3 - continued

By; Martin Ford, Mike Ford, Mike Hewitt & Gerry Howard

**May 21<sup>st</sup>** – The overnight snow had persisted, although it was evident that

the ploughs had been out during the night. The main roads were clear and even the car park wasn't too bad. Based on the amount of snow on the Acadia there had probably been 6 - 8 inches of snow overnight. We had allowed sufficient time in the early morning alarm call to ensure we had enough time for breakfast irrespective of the weather conditions. In the end it was being over cautious, we made the journey across town without too much trouble before returning the hire car to the Alamo depot. The shuttle bus got us to the airport with the necessary 2 hour buffer before departure. Checking the big bags caused minor trauma as one of them was overweight. The hold baggage weight limit on Delta and most others is 23 kg (50 lb in old fashioned money) and we were over, too far over for the check-in clerk to let it pass (\$100 surcharge for any part thereof of the next 20 lbs). A quick transfer of



clothing to carry-on baggage brought the weight down to a limit the attendant was prepared to tolerate. We were still over, but not far enough for him to worry. We decided to further redistribute the weight before the return transatlantic flight.



*The snow covered morning view from our hotel window, Denver CO (Martin Ford)*

Inside the building it was time for the ordeal which was security screening. We got a heads up on the quickest line (not queue) to take, but unfortunately encountered a trainee X-ray operator who flagged up a suspicious piece of hand baggage and Martin was summoned to explain. Ironically it was Mike's bag that Martin was carrying, so Mike missed a close call there. The secu-

rity staff's concern was easily explained, as the castings of a white metal kit were particularly dense and necessitated closer inspection. Fortunately, the kit was in the end pocket of the bag, so all the laundry and other train stuff didn't need to be disturbed. We resolved to send the kit through as a separate item during scanning before the return flight. Having got dressed again; putting belts, shoes, watches etc back on, we encamped by the gate to await boarding.

The flight to Seattle was uneventful with the pilot making good time in spite of turbulent weather which necessitated the 'fasten seat belt' sign being lit most of the flight. All the baggage arrived safely and having waited ages for the shuttle bus to the hotel we finally managed to check in. After a breather we set off in search of food, but this time, unlike our previous experience at Denny's, it was a bad experience. Needless to say, the tip was not generous. We then reconnoitred the rapid transit station for fare and schedule information for tomorrow's sortie into Seattle. A visit to the bar was in order, followed the necessary repacking of the baggage.

**May 22<sup>nd</sup>** - We checked out of the hotel, but left our bags for safe keeping in the hotel lock-up. We headed for the light rail station (SoundTransit). Tickets purchased (only \$2.00 for a return journey to Pioneer

Square in downtown Seattle if classed as a senior - not much more for an adult). The train arrived on time and the journey into Seattle was completed in about 30 minutes. The train was clean, light and comfortable. The journey on the elevated sections of track provided good viewing of the surrounding areas. We headed off to the sea front to do touristy stuff and take in the sights. The weather was with us again this time necessitating the purchase of ice cream.

Wandering down the sea front the sound of diesel horns was heard but could not be seen. Continuing along the front all of a sudden two main line tracks appeared to our right with a BNSF grain train emerging into the daylight. As it came to a halt, we crossed the road for closer look. More sounding of horns and the grain train was passed by an empty coal train with two on the point and a DPU. Obviously, a priority movement. The grain train was finally given a release to proceed and as it pulled away another empty coal train with two BNSF units and a UP unit on the point (one DPU) passed travelling in the opposite direction. This was a really good vantage point for watching trains, it was a pity we had come across it just when it was time to start heading back to Pioneer Square for the return light rail journey.



*An Ex Santa FE GE AC4400 #731 backing up #5776 still wearing it's red & silver Warbonnet colours, Seattle WA(Mike Ford)*

We made our way back along the sea front, stopping to watch demolition work of a disused elevated waterfront rail/road way. There was a lot of development going on at the waterfront, but the demolition works were attracting a larger audience than the normal touristy stuff. Large excavators and demolition machines trying to break down heavily reinforced concrete pillars and supports were proving really popular. We made it back to the rail station for the return journey back to the hotel in order to collect our bags. The hotel shuttle bus

delivered us to the airport and following check-in we cleared security screening, but not without the white metal kit again causing the X-ray machine to throw a wobbler and the bag being selected for further investigation. Another satisfactory explanation was provided and no further delays were experienced.



*220519 - BNSF GE #5776 on the point of a grain train awaiting a green signal on the waterfront in Seattle WA - (Mike Ford)*



*A view out into the Puget Sound from the waterfront, Seattle WA (Mike Ford)*

**May 23<sup>rd</sup>** - We transitioned into the 23<sup>rd</sup> whilst somewhere over Canada/Greenland. The flight was shorter than scheduled by 15-20 minutes, but still not short enough when leg room is limited even in an Airbus 300. Unless you buy extra leg room in business or comfort class it appears airlines don't consider extra leg room for the 'cattle' class, especially on long haul flights. The transfer in Dublin was trouble free and we had a couple of hours to kill, but the persistent discomfort from being cooped up from Seattle did not permit much in the way of exploring. We were just happy to get on the plane for the last leg of the journey.



The flight to Manchester was quick, no sooner had the pilot lit the blue touch paper than it was time to glide in over Anglesey. We did some train spotting from the air, but unfortunately these were sprinters and the like, not proper trains so we put the 'I spy of railroads' book away. The path through the 'green lane' was stress free and our practicing of the innocent walk whilst whistling proved unnecessary. In the arrivals area we assembled and waited for Gerry to make contact with our taxi driver, who should have been loitering in close proximity ready to dash in and collect us. This is where it started to unravel. Some sort of incident on the M56 had thrown the roads surrounding the airport into chaos and it was gridlock everywhere. We seemed to wait for hours, but in reality, it was probably only 30 minutes or so when eventually the minibus turned up. We left it to the driver to pick the best way back to Gerry's where we decamped, redistributed the contraband and awaiting the pre-arranged lifts to return us home. Typical that we'd covered a lot of miles in the States without witnessing anything more than a minor shunt, only to get to the UK and the road network grinding to a halt because someone who shouldn't be driving has run into someone else who shouldn't be driving. Nuff said.

## **Some statistics**

Air miles - approx. 11,700

Rental vehicle miles - 4,000

Walking miles - not quantified

Number of states visited - 7

Average fuel cost (regular gasoline) - approx. \$3 per US Gallon

Approx. cost per person (excluding personnel purchases such as souvenirs etc) - \$3,500

**Would we do it again? Of course!**

---

*Note from the MRE team*

*We have absolutely loved reading about Martin, Mike, Mike & Gerry's amazing adventures in the USA. And we hope readers have enjoyed reading about them too.*

*If you've been lucky enough to do a trip like this we'd love to hear from you and to publish your stories and pictures.*

*Please contact [editor@mre-mag.com](mailto:editor@mre-mag.com)*



WINELANDS  
LIGHT RAILWAY  
**OPENING**  
**14 DECEMBER**



FOLLOW OUR PAGE FOR MORE  
INFORMATION AND REGULAR UPDATES

<https://www.facebook.com/WineLandsLightRailway>

# The Station Master's Apartment, Strathcarron, The West Coast of Scotland (on the A890)



By James Humphreys

Strathcarron Station Master's House is a real gem.

It is a building on an in service station near the western end of the Inverness to Kyle of Lochalsh line. Strath describes a flat wide river valley or the grassland along it, from the Scottish Gaelic “srath”, the first usage of which being in 1508. A Sea Loch, Loch Carron connects Westwards to the sea and the village is at the North East end.

The main station building has undergone a complete renovation and is divided into three tasteful holiday apartments. The ground floor is divided into two apartments (one was almost finished when I stayed there) and encompasses the ticket office, waiting room and a signal room amongst others. The signal room complete with the original levers and some other fittings forms part of a kitchen.

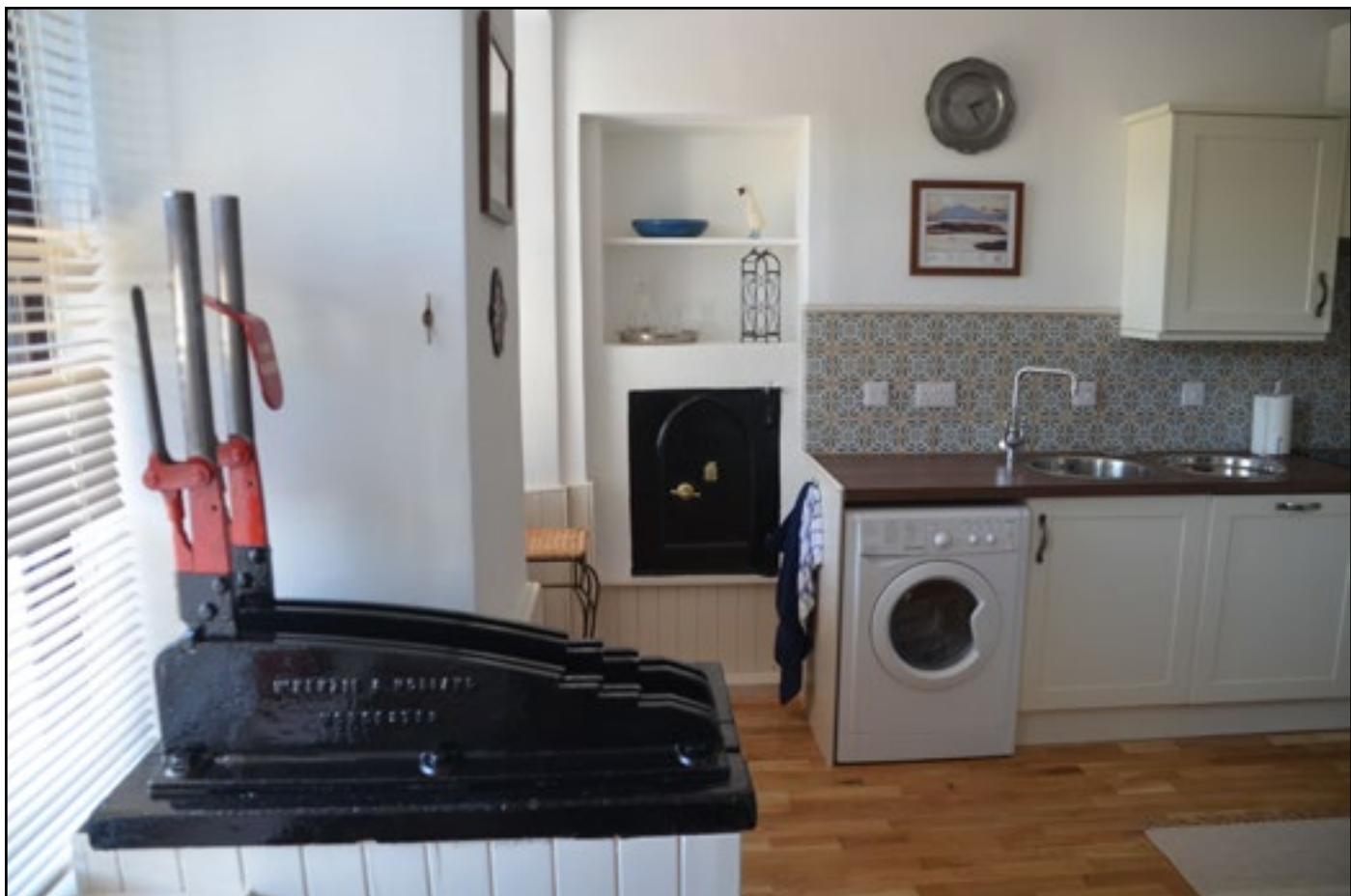

The first floor used to be the apartment for The Station Master. The three apartments are entered from the station approaches and do not have doors directly onto the platform. The Station Master's apartment will comfortably suit two couples. It has large windows in the living room and kitchen/dining room that face the platforms, affording an excellent view of the infrequent comings and goings (eight trains on a weekday). Double glazing means that little noise is heard and we slept through the first arrival on our "lazy" day.



The Station Master's apartment is a "cut above". It was intended to be a main residence and this shows in the attention to detail and the quality of the fixtures and fittings. Parking is directly outside the gate to a small gravelled courtyard with a fence high enough to ensure privacy for sitting outside. The entrance hall contains a washing and a drying machine, a shoe rack (no outside shoes upstairs please) and the stairs. Another door leads to the carpeted hallway with a niche containing a roll top desk and convenient electrical sockets. Two double bedrooms (one en-suite), a further shower room with underfloor heating, then a large living room with La-z-boy suite and a very well appointed kitchen

with a dining area that could seat six easily. Remember, this was designed as a main residence so everything is of a high standard; A Bosch oven, a dishwasher (In a holiday rental??!!), high quality accoutrements and Brita filtered water from the kitchen tap. The carpeting is tasteful but clearly with a superior underlay and if one added a few family photographs it could easily be one's own home.

A suspicious observer might just detect that I am rather enthusiastic about the place. Well, that is down to the vision of the owners. I believe that when I am trying to find somewhere I have not been to before, the directions should enable me to find it at night and in a snowstorm, let alone in daylight. First tick in the box. Then, to find a pint of milk in the fridge, a complimentary bottle of very quaffable wine in the rack, a comprehensive explanation of where everything is and how to turn it on/off and a good selection of ideas with brochures for where to go, where to eat etc. was an excellent welcome. Seriously, the folder was an inch thick and packed with ideas and advice. Second tick in the box. My back has seen more carefree days so a comfortable bed was a huge plus. The bookcase (in a rental????) contained an eclectic mix of local/specific and generally informative books as well as a good selection of really readable books; If only there had been

more time! I swear that I reluctantly left where found, the Anthony Beevor! The sound system had a seemingly inexhaustible supply of classical CD's. Bluntly, after the long drive discovering the delights of a la-z-boy and the bottle of wine made sleep a doddle.

I think the owners have got it right, if you treat people to the standards that you expect for yourself, visitors can be trusted not to appropriate books and will treat the venue with respect. I earnestly hope that this view of human nature is proven to be correct.

Strathcarron is delightfully remote but conveniently if you do not want to drive, you can arrive from e.g. London by train (you have to connect) and use the line to get about. At Kyle of Lochalsh for example, you can walk onto or catch connecting buses into, The Isle of Skye or, take a short stroll to an ex-signal box that doubles as holiday accommodation downstairs and a model railway display of the line near Kyle. Book ahead if you want to eat at the seafood restaurant on the station at Kyle. Seriously, book ahead it is worth the bother.

The location is fantastic whether you want to visit Skye, push North or inland to Glencoe, want to keep your eye in regarding railway things or just want a quiet spot to calm down and mosey about or to do some serious hill walking.



The peninsula of Ardnamurchan is within striking distance and is superb; Beaches reminiscent of those in The Caribbean and with a micro-climate that supports a different floral ecosystem to the rest of Scotland.

Right, the above is what you show your far better half. Now for what you really came for! The Royal Scotsman stopped for a while one morning. Unfortunately I am not a morning person. However, you should be able to easily find out when it will do the journeys up and down the line. If you see it go towards Kyle in the evening you can be sure that it will be coming the other way the next morning (approx. 0730-0845).



Please note that the picture was not taken during my stay and features a different engine from the usual one. The other train is The Mayflower which visits occasionally.



If you are really into track then you may well have a more informed view on the state of the sleepers in Strathcarron, but my layman's view is that trains stop there because they need to allow the track/sleepers/track bed to calm down before they go any further. Fans of railway crossings will enjoy the one at the west end of the station.



If you have a passing interest in ferries (check the exact routes) then, it is possible to get from Skye (Armadale) to Mallaig (the western terminus for The Scottish Highland Railway) or you can drive Eastwards. You already know where this is going! So, let's get The Glenfinnan Viaduct out of the way. It was raining very hard and the walk to and from it could be better signposted especially as parking was a form of suicide lottery given the weight of traffic. However, let's face it, CGI is an amazing phenomenon. The viaduct itself might be a great piece of engineering but it bears little resemblance to what is shown in the Harry Potter films.

My holiday was focused on The Isles. Distances were in my opinion, very reasonable to Skye, short to Castle Eilean Donon.



Book any restaurant within 30 miles ahead of time in the main tourist seasons. We did not go inland or North from Strathcarron though we would have done if we had had an extra day (we stayed for three nights with a major journey before and after arrival so had only two days in the local area and it was not enough).

Clearly I was really very impressed with The Station Master's House at Strathcarron. The owners state that adults only should stay at the property. I agree, the proximity to the in use railway line means it is unsuitable for small children. The ethos of MRE is to be positive about what is good and to avoid criticizing things that aren't (e.g. the second stay on my trip). Let the praises resound!!

### *Postscript/disclaimer*

Note: All fees were paid privately at full price and no future discount or incentive has been offered nor will be accepted. The views expressed in the article above are solely mine (other than the influence of my far better half), and may vary from what you think constitutes a great place to stay. In this case "Vive la difference". The author of this article is not related to, nor knows socially, through business or otherwise, the owners of the accommodation described in the article.

A link to the owner's website is available here [www.strathcarronstation.co.uk](http://www.strathcarronstation.co.uk) . If you decide to give it a go then I hope that you have as good a time as we did.

# Railways at Night From dusk til dawn

Author: Robin  
Coombes / Taliesin  
Coombes

Price Special Price:  
£17.99

ISBN 9781445692371

Size 168 x 126mm

Binding Paperback

Illustrations 125

Published by Amberley Publishing

Review by Cath Locke



This is possibly one of the best Amberley books I've had the chance to review. It's another offering of photos but what stunning photos!

This is Robin and Taliesin Coombes' second book and looks at railways at night beyond just the UK (their first book was *Railways in the British Landscape*, also published by Amberley).

In the introduction they note the advances in photog-

raphy technology over the last decade which has enabled such low light photography and also (although still a challenge) capturing a train at speeds of 70mph (such as the picture of the class 253 at Dawlish).

Not only are they stunning photos of the actual subjects but the settings are also atmospheric. And widely diverse.

From Clun Castle crossing the M42 at dawn to the snowy and misty picture from Crich.

The opportunities provided by subjects picked out by floodlights, emerging dawn light or their own light (there are some stunning pictures of welding and firing) make for an absolutely fabulous set of photos.

Possibly one of the best set of collected railway images from across the world I've seen. Thank you Amberley for sending me this one to review!

*'Coal-black starless nights, comfort only from the weak glow of station lamps. The velvet silence broken by a series of shrill ringing bells in the signal box, a flurry of activity; levers are pulled, wires sing, signals drop, and silence returns. In the far distance a quiet rhythmic beat, the gloom pieced by a star of light, glinting off silver rails. A sudden rush of billowing white steam, gleaming paintwork, polished brass, and flying pistons. Passengers snug and warm in their car-*

*riages. All over in a fleeting moment. A disappearing tail lamp is the only evidence of an everlasting memory.*

*Robin and Taliesin have set out to capture the drama of railways between dusk and dawn. The selection illustrates behind the scenes shots of engine sheds, wayside halts and busy city stations and the people who work the night shift; all captured in a series of beautiful photographs that will be revisited again and again.' (Amberley Publishing)*

---

# Skytrex Model Railways

Building kits and scenic accessories

In O gauge and OO gauge

[www.ogauge.co.uk](http://www.ogauge.co.uk)

[www.skytrexmodelrailways.com](http://www.skytrexmodelrailways.com)

Tel: 01509213789





# **MODEL RAILWAY EXHIBITION**

**Ely College**

**Downham Road, Ely. CB6 3DY**

**Saturday 16 May 2020**

**10:30am to 4:30pm**

**AMPLE FREE EXCLUSIVE PARKING**

**Ely and District Model Railway Club**

**Adults £5.00 Children ( 5-16 ) £3.00**

**Under 5 s Free**



Elymrc reserve the right to refuse admission

[www.elymrc.org.uk](http://www.elymrc.org.uk)



Clip Art courtesy of

<http://clipart-library.com/train-drawing.html>

# Midlands Garden Rail Show

SATURDAY 14<sup>TH</sup> & SUNDAY  
15<sup>TH</sup> MARCH 2020  
WARWICKSHIRE EVENT  
CENTRE



Transport yourself into a world of inspiration at one of the leading model railway events dedicated to garden rail. Featuring the larger gauges this show takes celebrating your passion to a whole new scale!

The annual event is set to fire on all cylinders with a diverse array of layouts to represent a variety of gauges. Take the opportunity to marvel at each layout, and wonder at the incredible craftsmanship, brought along by exhibitors for your enjoyment. From historical recreations to fictitious lines each layout offers a wonderful glimpse into the many ways that an interest in Garden Rail is the chosen hobby for so many enthusiasts.

Knowledgeable exhibitors will be available to demonstrate how not only are these layouts aesthetically pleasing, but also the practicalities and running of locomotives on them. Watch the layouts come to life,

creating a new depth and giving the ability to lose yourself in the beauty of the working locomotives including live steam, gas and coal fired!

The exhibition is well supported by local and visiting clubs this year we shall have the honour of National 2 1/2" Gauge Association, B17 Steam Locomotive Trust, Gauge 1 Miscellany and Bromsgrove Society of Model Engineers joining us.

Pull into over 35 leading suppliers and leave their stations with locomotives, rolling stock, track and accessories to head home and create the layout of your dreams.

Don't let this train leave the station without you. Join like-minded enthusiasts. Enter a world where the only limit is your imagination.

Midlands Garden Rail Show takes place at Warwickshire Events Centre on Saturday 14<sup>th</sup> and Sunday 15<sup>th</sup> March 2020.

For further details on the exhibition and suppliers attending please see;

[www.midlandsgardenrailshow.co.uk](http://www.midlandsgardenrailshow.co.uk).

## Opening Times:

10am – 4pm Daily (last admission one hour before closing)

## Admission Prices:

	On Line*	Full Price**
Adult	£8.00	£9.00
Senior Citizen	£7.50	£8.50
Child (5-14)	£3.50	£4.50

\*On Line - Tickets are available via the website at discounted prices until midnight Tuesday 10<sup>th</sup> March.

\*\*Full Price - Tickets are available on the day from the ticket office.

**Website:** [www.midlandsgardenrailshow.co.uk](http://www.midlandsgardenrailshow.co.uk)

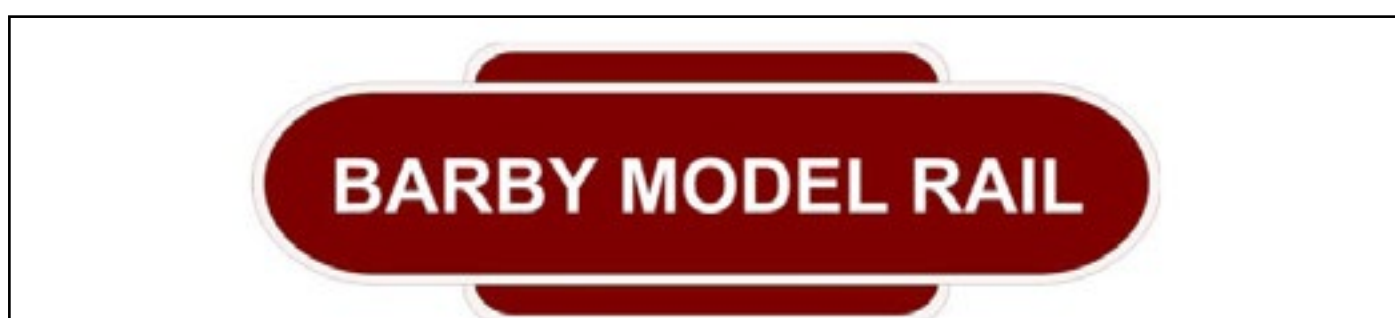

# Severn

# Models

**WE SELL ALL MAKES, MODELS AND ACCESSORIES**

**MODEL TRAINS & ACCESSORIES**

## RAILWAY CONDUCTOR



**Also Die Cast - Plastic Certified - Toys - etc.**

**T: 01327 438738**

**M: 07881 757084**

**Email: [jonathan@severnmodels.com](mailto:jonathan@severnmodels.com)**

**[www.liveringhamsconductor.co.uk](http://www.liveringhamsconductor.co.uk)**

**Unit 2, The Old Dairy-Cell Centre, Upper Street, Hovingdean off A5, Northamptonshire NN4 4SH.**

**OPEN 7 DAYS A WEEK**

• Mon-Fri 10.30-17.00 • Sat 10.30-17.00 • Sun 11-15.00  
out of hours please call mobile - thunker

**NEW AND USED OO & N GAUGE  
SOLD AND BOUGHT**



**Mail order available by phone or visit us online.  
All major credit and debit cards accepted.  
We accept PayPal through our online shop.  
We now do repairs and servicing and we build layouts**

**LCUT CREATIVE**



**Modular laser cut kits  
Available in O gauge**

**LCUT CREATIVE**



**Modular laser cut kits  
Available in OO gauge**

## Soundtraxx announces new 21 pin mobile decoder



DURANGO, COLO – SoundTraxx announced the release of a new mobile decoder, MCIH104P2I.

The MCIH104P2I mobile decoder easily plugs into many Athearn or other manufacturers' models equipped with a 21 pin motherboard. This decoder is also compatible with other SoundTraxx mobile decoders and products. The MCIH104P2I has a max stall current of 1-amp, 4 function outputs, 15 Hyper-light effects, 28 point speed table, and operates in NMRA DCC only.

**P.N. 852005**

**MSRP: \$23.95**



SoundTraxx decoders are designed and manufactured in the U.S.

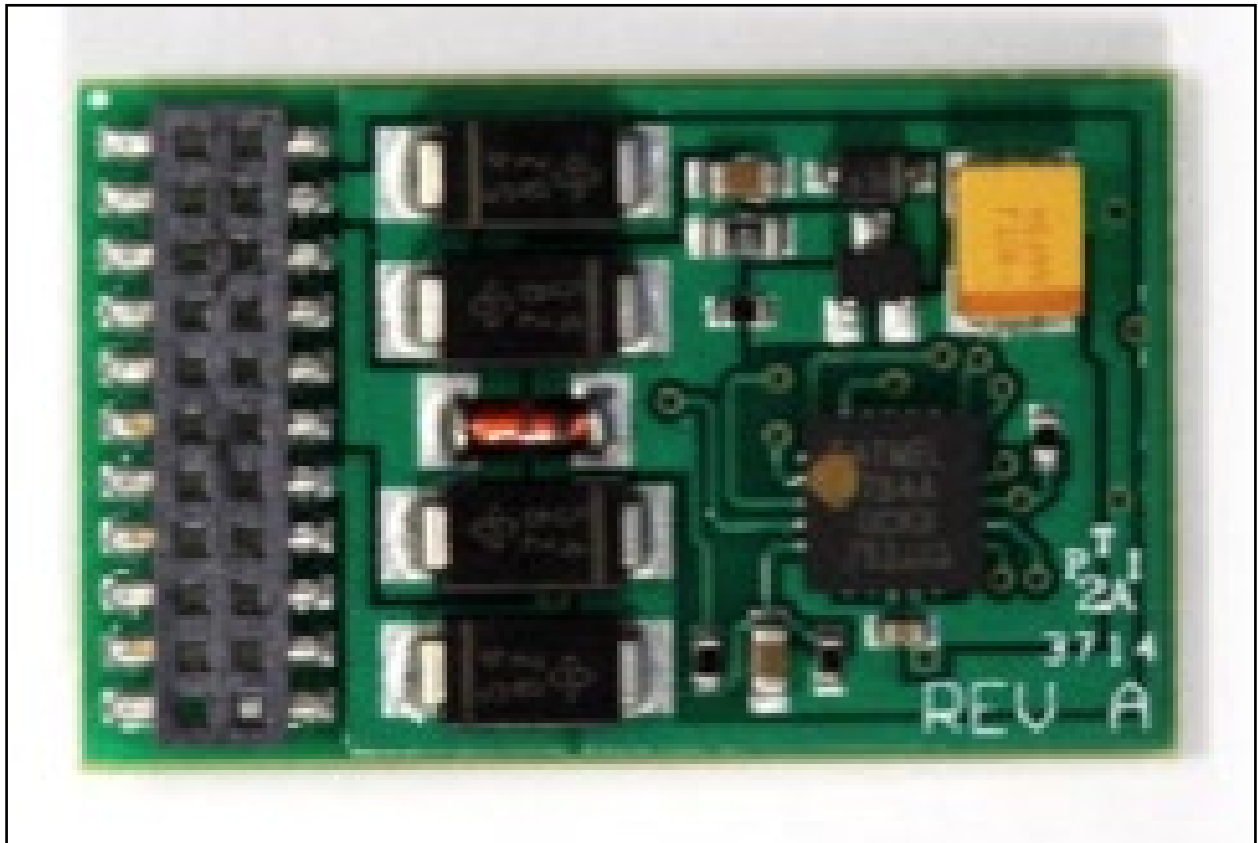

SoundTraxx

141 Burnett Drive

Durango, CO 81301

(970) 259-0690, FAX (970) 259-0691.

[sales@soundtraxx.com](mailto:sales@soundtraxx.com)

[www.soundtraxx.com](http://www.soundtraxx.com)

# “When you’re on the outside Looking In...” Thoughts on Great Central Railway’s Exhibition

By James Humpreys



An old friend asked me to help his model railway club with unskilled lifting and carrying at the Great Central Railway Exhibition near Leicester in June '19, in order to give feed-back on the event.

This is a distillation of my impressions not a description of the event itself. It was made clear to all people that I chatted to or interviewed that I was from outside of the modelling world. Whilst I have tried to be objective inevitably the article contains my subjective views and opinions.

## **The Exhibition**

Two marquees each about the size of a football pitch joined together, next to a Heritage railway station with easy parking within a few hundred metres and disabled parking closer. The event was well organized with plenty of signs, food outlets (the bacon/sausage with egg



baps are heartily recommended), lavatories and many helpers to guide and advise. A lot of effort was made to evoke the spirit of the 1940's at the station and numerous trains of all descriptions ran regularly for the benefit of devotees and children. Whilst this was a huge draw the focus of the article is on the exhibition itself. There was a wide selection of exhibitors with a high ratio of top quality layouts which helped to ensure that there wasn't an overly commercial feel to the event. Michael Stokes explained that this was GCR's sixth annual exhibition and that approximately 6-8000 visitors were expected. To summarize Michael said "Travel behind the real thing to see the model". This encapsulated the vibe that I picked up. It would be easy to forget that the trains don't just run from the station the event is at but also deliver attendees from the stations along the route. It might seem to some like stating the obvious but, the trains fulfil their original intent despite being heritage trains.

## **Overview**

Quote "We are impressionists. What we model is not reality but, if we have a good day then we can trick the eye into thinking it is real".

The exhibition was not at all what was expected. Bluntly, you lot could teach zen masters a thing or two about harmony. The level of happiness and contentment at the event was a pleasant shock. It was not so much that it was there at all (it is to be expected at an event for people with the same interests) but, that the elevated level was maintained consistently across several days. Talking to a lot of people confirmed that it wasn't just a chance observation. The pleasure gained from the event was all pervading and was all the more impressive as it was a controlled enjoyment rather than for example, the euphoria of fans when their side scores a goal followed by the nail biting of the final few minutes.

## **Some impressions from talking to people**

There is a tangible *sharing attitude* that is all pervading. A number of people at the exhibition showing off their skill(s) with a view to earning money, were extremely helpful. Far from "I know a secret..." they were unhesitating in their desire to show exactly what they do and to explain how people could do it themselves whilst being disarmingly humble about their skill. Richard Wilson "Weathering is just bad painting. I can get away with it", is IMHO an artistic genius. What he painted in front of me in just 20 minutes was astounding. It takes a bit longer to achieve the amazing end results on dis-

play. For the avoidance of doubt, it was truly humbling to talk to a person who is such a master of his craft, whilst he answered my anodyne questions and added helpful tips e.g. which types of paint to use for different effects and, how to achieve 3D effects that are out of absolute scale but, that look right to the eye because they add depth.

One gentleman explained that he was most of the way to the exhibition five years ago but that he had had to return to London (several hours away) when he received a message that his wife had gone into labour. He was thoroughly content to finally attend and seemed to harbour no grudge at having being thwarted five years previously! He was one of the happiest people I have ever met. We discussed exactly what he wanted to see for some time. Some hours later we bumped into each other as he was leaving. He was still as happy as when he had arrived.

## **Ladies**

A number of ladies (wives or partners) accompanied the modeller. I had assumed it was out of dread duty and that the husbands must have recently performed decorating miracles. Far from it! Modelling does seem however to be generally a bargaining tool (and not in the favour of the modeller) in relations with “The

Laager Fuhrer”. The following is a subjective approximation:

- Approximately 80% of the “wives of modellers” had a positive view of the affliction irrespective of how they do or don’t provide feedback to the modeller. Most of this group (approx. 60%) actually envied the interest and satisfaction their partner.
- Approx 5% took the view that they knew exactly where their deluded partner was, who he was with and when he would be home. There was a clear wish for an interest in something more useful e.g. Thai Dying, curtain making or whatever. Generally though the view was that whilst the interest was “playing with trains” this was to be encouraged as it is far better than some alternatives.
- Approximately 15% not only envied their partner their chosen outlet but bought into the idea and were happy personally to get involved. This was almost exclusively on specific artistic elements e.g. foliage.
- A very small percentage (not statistically relevant), were into the whole thing and liked running trains. So chaps, the perfect match could be out there!
- About 35% (mostly from group 1 above) had a positive view and whilst they had no interest whatsoever themselves, were happy to accompany their beloved

delusional to exhibitions etc. as it had benefits e.g. a nice lunch, keeping an eye on the chap, it isn't as boring as the last boyfriend's irrational love of pigeons, etc.

- About 3% hated the whole thing, were clearly there under duress and by god were they going to extract revenge in the form of Aunt Mildred coming for Christmas etc.

The percentages do not add up due to there being cross overs between the groups.

Being serious though, the conclusion is that a lot of wives/partners recognise that their husband/partner needs a hobby and are happy to tolerate it within reason. More positively a fair number are supportive and for reasons that perhaps are not made explicit e.g. artistic outlet, socialising in a "safe/acceptable" way. I think it is simply another example of women knowing their men rather better than the men realise.

*Note:* Questions were specifically asked about lady members of clubs and how to increase the numbers. Answers were all positive, clubs would like more. Of the fair number of women who expressed interest, their reservations were generally split between balancing time (children/their other interests), a view that this was something their husband/partner did and most interestingly, a desire not to tread on the toes/suffo-

cate their husband/partner. One quote was “I know where he is and who he is with. If I joined the club he wouldn’t have anything to tell me when he got home and he would think I was ruining his hobby”. I think this is worth dissecting and certainly anybody with a view would be most welcome to write an article for MRE from whichever perspective. It should be pointed out that there were a number of couples who have an interest in modelling. Are they/you lucky or extremely in tune? Please do tell MRE what you think.

With regard to increasing female membership, I think it is a chicken and egg situation. Ladies like to socialize so do not necessarily want to be the only woman in a club. Some “wives of” might be a little less accepting of their partner’s hobby if it is not in a male dominated environment. Now that is a second set of articles/views right there!

## **How did you get into modelling?**

It seems like a very simple question and frankly, the answers were very simple. The percentages exceeding 100% are due to people stating multiple points.

- Approx 90% - I had a layout as a child. I loved making things happen and controlling what happened. Dad/Granddad encouraged....Then I discovered girls...

- Of the above, approximately 95% said: I didn't/couldn't maintain my interest in trains but in later life when looking around for something...
- Approx 90% - Three main groups:
  1. Children moved out so there was a spare room. This group split fairly evenly into, I won so have a layout in... and, "So that is why I spend my time in the shed. It is quite a nice shed really".
  2. I retired and it was a choice between death by supermarket, local politics or this. I made the right choice.
  3. I am older now and have the money.
- Approx 90% - I wanted an artistic outlet. A smaller percentage added "I can't paint so decided to model trains".

The key point is that the hobby was not new/entered into cold. They had had a layout as a child and so it was a "known" thing.

There was also a longing for a "safe" artistic outlet and this could be achieved by creating the sort of layout they wished they could have had as a child. Additionally, I think there is a conscious or unconscious desire for a "manly" interest. It isn't real steam engines that are powerful and impressive but, it is based upon them. It is perhaps unconsciously seen as a "safe" artistic outlet

in building/engineering/ a love of steam power or nostalgia generally.

An easy entry to railway modelling is achieved by having the money to “short-cut” some entry barriers e.g. having initial talent. This is unfair perhaps but I believe it to be a partial truism.

The one question I wish I had asked was “Why railway modelling instead of for example military modelling?” I think the answer is very simple. Most children in the 50’s to the 80’s who later got into either had access to one or other or both as a child. It is simply which one resonated the most deeply in the memory as an adult. The conclusion is therefore that the gift of a trainset to a grandchild or child is a seed corn for the future. More than this, perhaps the reason men are more interested in the hobby than women now, is that (rightly or wrongly) 40 years ago boys played with trains and girls “didn’t” so today’s women do not have that childhood memory that many men do.

Note to all grandfathers; Trainsets for granddaughters!!

## **What Do You Think Your Wife or Partner Thinks of Your Hobby?**

This is a separate heading as it is what modellers thought their wives/partners think. A large majority of respon-



dents felt that their spouse or partner is supportive generally. Certainly they felt that things could be made a good deal harder! There was acknowledgement that it had to take a back seat to the numerous responsibilities and duties inherent in life, but that generally there was appreciation that they are able to pursue an interest relatively freely. There is give and take in any relationship.

There was no upset or feeling of encroachment where their wife or partner is interested in the hobby, quite the reverse. There was great pride in a wife or partner that has an interest (almost always) in an artistic element and always followed by a comment on the lines of “She is much better at that than I am”.

This appreciation for anybody with a talent, and acceptance that one might be good at one part but that there are others who are far more talented at others was universal. I did not meet one single person who thought they were good at everything and very few who seemed to think that they were really good at any one thing.

## **The Future**

IMHO a sea change in hobbies is happening almost unremarked upon. If we go back to say the 1950's to

80's I believe that a lot of the games of children were "simple" and very imaginative in that the child had to imagine them for themselves. My own childhood (born 1964) was filled with Lego and Meccano, all bits picked up from who know where and certainly not intended to make a specific model (or at least not by the time I got them!), that meant that anything was possible.

Today, imagination comes pre-packaged in truly amazing video games that Wow the players. I still remember the first time at approximately age 8 that I first saw a colour TV. The world changed at that moment. Now it changes every time HD is replaced by VHD then UHD etc. Presumably the next will be CHD (Cosmic). The games are almost if not actually better than reality and certainly more exciting. The issue will be how to capture the imagination of people brought up on this super-reality when what is on offer is unfamiliar perhaps alien and, requires personal imaginative effort?

The key issue to me is the element I was most appreciative of, the long, sustained happiness as seen at the exhibition when contrasted with the very quick fix high adrenaline, instant gratification of video games.

I watched two gentlemen having a discussion about how to control a layout using a mobile phone. I am not casting stones as I have no idea. However within seconds of putting the phone into the hands of an 8

year old, the kid was able to run a specific train along a piece of track and not break anything. Of import was the satisfaction that the child had in controlling something real as opposed to an animated character. That young chap loved making something real do what he wanted and from his reaction it was more satisfying than what he was used to.

Therefore I don't have a conclusion on such a small sample. Innately I urge perseverance in "capturing them young" but, I think there will be problems in attracting people to the hobby in as little as 15 years' time. A number of clubs have clearly done well in attracting younger members and they appear to have embraced technology in enhancing the hobby. I see no difference between adding realism by using IT opportunities and the traditional weathering and scenery for example. If wiring up a layout to include lights that turn on and off in houses, noises and electronic signalling enthuse younger members then that is good. Some will say it is not necessary and that is fine as well.

The key is to make space for the interests of others in order to enhance the whole rather than for everything to wither on the vine.

## Would I Go Again?

Yes. I am rather surprised to be so certain given my reservations before going last time. It was an enjoyable experience and next time I will have a chance to talk with people who make the heritage trains and system work. I have a lot to learn.



**TONY'S TRAINS**  
AT BARBY MODEL RAIL

New and Used Model Railways. Hornby, Bachmann, Heljan, Dapol, PECO, Oxford, Gaugemaster and more....  
Large selection of 2nd hand models. Mail order available, pre-orders welcomed.

Open: Tuesday to Saturday 10AM - 5PM (4PM on Saturdays)  
Tel: 01788 543442 email: tony@bmrail.co.uk web: www.bmrail.co.uk  
Studio 3, The Locks, Hillmorton, Rugby, CV21 4PP

**WE BUY YOUR MODEL TRAINS**  
GOOD PRICES PAID, PLEASE CALL TO ARRANGE A VALUATION



# MODEL RAILWAY

# EXPRESS

eMAGAZINE



**Model Railways  
By Enthusiats  
For Enthusiats**

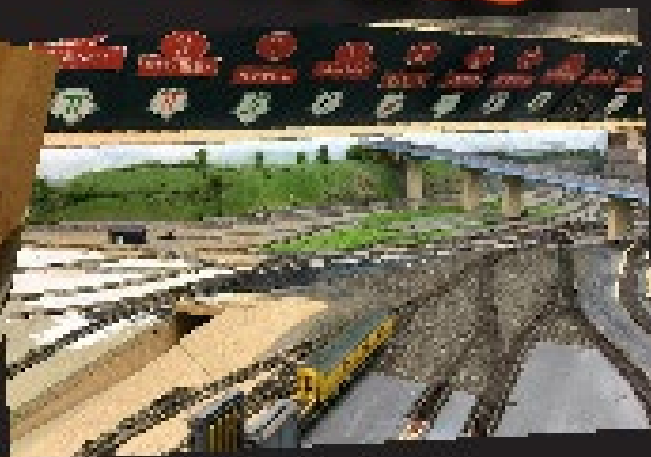

**WWW.MRE-MAG.COM**

**Railway Refreshments - International!**

## **Franschhoek Station Pub & Craft Bar**

By Terry Rowe



Franschoek is about 75km out of Cape Town and lies between Paarl and Stellenbosch. In the late 17<sup>th</sup> century French Huguenot refugees who had arrived in Kaapstad (Cape Town), at that time part Dutch East India Company, began settling the area. They established farms and other agri-



*The original station building*



*And today*

cultural businesses - many of which have since grown into well known wineries.

The area retained its French heritage being initially known as le Coin Français (“the French Corner”) before being renamed as Franschoek (which is Dutch for “French Corner”) and through the many French family and place names which the settlers brought with them from their homeland.

In 1904 the railway line from Paarl to Franschoek was opened for farmers to get their produce to market and also to receive goods and post themselves and connect them to the wider world.



*The outside covered bar*

Originally built in 1915 the station building is a protected. Eventually, as all over the world, road transport improved and after diesel replaced steam, that too disappeared and services ended at the end of the 1990s.

In November 2009 and the much loved station building was restored and the Franschhoek Station Pub & Grill was opened. In 2013 new owners Andre and Sandi Niemand changed the name to The Franschhoek Station Pub and Craft Bar.

It offers an extensive menu and serves food from breakfast through lunch to all the way to dinner.





*Malva Pudding and Ice-cream*

Serving traditional desserts, the highlight for me was the Malva Pudding, which is an absolute must. It's a sort of South African 'sticky toffee' type pudding, very yummy.

They also offer Biltong tasting and a DIY braai (BBQ) option. The old station area has been covered over with a large canvas awning, providing shade from the hot African sun. As you might expect, the wine list is entirely South African and there is also a large selection of craft beers (some with very inventive names!).

The food was excellent and the service was very friendly. This is a must stop off and call in place while visiting Franschhoek.



*Traction engine-re farming*



*Local craft beer for that un-wanted guest !*

# Paul's On30 page - making the most of your flat cars

# On30

By Paul Davis

Probably the cheapest cars you buy are flat cars and they certainly are the cheapest and easiest to scratch build. They are also the most versatile. This is one of the ways you can make the most of your flat cars with just a few coffee stirrers some matchsticks and plastic strip. I will not be giving any measurements as it depends on what flat car you are using; I am using a scratch built one so probably different than any commercial RTR/Kits you may have.



*Basic flat car,*

Simply what I am doing is making removable bodies that can be interchanged on to any flat car of the same dimensions. The bodies I will be making are very easy -some more than others- starting with a low sided gondola -easiest build- high sided gondola, and stock car.

**LOW SIDED GONDOLA;** Easiest and quickest to build. Take a couple of your coffee stirrers and cut to length- about half the length of the car, cut two more the width of the car, glue into a square re-enforcing the corners with small bits of matchsticks.



*Low sided gondola*

Depending on what height you want you can add one or two more layers (the matchsticks in the corners obviously need to be longer to re-enforce the corners), making it one two or three coffee stirrers high. Add 3 or 4 matchsticks evenly spaced on the outside to act as stakes these need to be the same height as the side of the gondola plus the depth of the car side frame. DO NOT glue the body to the flat car if measured correctly the side stakes should hold the body tight to the flat car. (see photo)



*Low sided gondola fitted to flat car*

**HIGH SIDED GONDOLA;**The same as above but 4 or 5 stirrers high and make the side stakes longer to take in the extra height and the depth of the flat car side.



*High sided gondola*

**STOCK CAR;** I built these in sections, I will give my measurements to give you an idea of what I am on about. I built four sections the same.

Take two full size matchsticks, I then glued four 5cm pieces of coffee stirrers across the matchsticks leaving a space between them and make sure at least 5mm of the matchsticks are left at the bottom to grip the flat cars sole bar, make four of these two for

each side the space between them is for the doors. The doors are made the same way, although no need to extend the matchsticks to grip the flat car and you need a couple of “L” plastic strips for the door slides, small bits of plastic off cuts to make the door locks and that’s the doors done. Next glue stirrers across the ends make sure they correspond to the boards on the sides, glue another board across the top of both ends cut to take the roof. Lastly add the roof I made mine from card covered with masking tape to give it the look of tar paper. A finishing touch was to use thin plastic strip to add cross members to the side.



*Stock car*





That's about it I now have three bodies for one chassis and the cost is negligible and there is nothing stopping you from making a box car or a tank car to sit on your flat cars.

*(above) End view of the stock car*

*(below) Flat car and two of the "removable" bodies.*



# Large Scale Tram Models to Operate at Crich



From April 2020, work at Crich Tramway Village will formally commence on a grand scale to build a 5¼ inch gauge model tram track by a small team of volunteers. This demonstration layout will result in some 11 metres in length for the 1/8 scale Robert Whetstone model trams.

This will allow the Robert Whetstone 1/8 scale model trams to be demonstrated to the public in the exhibition hall at Crich Tramway Village for the first time in over 25 years. The model trams that will be operating on the layout will be:

Birmingham Corporation open top double-deck tramcar 1 (opposite top) and Birmingham Corporation double-deck tramcar 18 (opposite bottom)

Project Manager, John Huddleston, said:

“The timbers have already been purchased and are ready for the big build. We had a lot of interest when

we ran model trams this year, so we wanted to go bigger and better for the 2020 season.”



# A Day in the life of..... Santa!

By one of the elves (aka James Humphreys)

A Magical Kingdom!



Every child should meet Santa at least once before the wonder of Christmas fades with growing up. But what is involved in providing the magical memories? Well, firstly it is an awful lot of work that has to be meticulously planned and with contingency plans for every possible permutation.

I had the chance to meet Santa in Loughborough. Unfortunately it could only be for a few minutes as I am sure you understand he is rather busy at this time of year. Santa was visiting The Great Central Railway with his great friend Mike Riley who was able to provide a great deal of information on Santa's behalf.

Mike has worked with GCR for ten years as a signalman since he retired and for the last three years has worked closely with Santa. He finds his role fairly easy as Mike has eight grandchildren.



During the week there are three departure times with a train going each way on the line so six in total. At weekends it is eight. Santa and his friends are therefore very busy. After that three Winter Wonderland trains depart and if that was not enough, special dining trains are also operating concurrently for Christmas parties and for those that simply want a memorable evening.

The cardinal rule for all the Santa Specials though is that at no point can two of them arrive at the same station at the same time and Santa has to be extremely punctual to ensure that he does not meet a doppelganger in front of the children.

Apart from all the station staff and drivers etc. there is a Train Captain responsible for overseeing everything and requesting extra stock especially age appropriate presents. Each carriage has a steward who serves drinks etc. who may lead carols and sort out all the typical issues that occur when children are involved. Two elves assist Santa with moving the presents along the train, a photographer is present on some trains and of course Santa himself. All the staff are DBS checked though this isn't strictly necessary as there is always a minimum of two adult staff together along with a lot of parents and grandparents. Most of the trains will have three carriages as this is the largest that enables Santa to spend some time with each child. The Santa Specials have a maximum of 175 guests and the de-luxe around 150 which allows Santa more time for photographs etc. Both trains have a split of around 60% adults and 40% children. Frequently groups perhaps a school class or interest group for example cubs or Brownies enjoy a trip together.

Mike gave a pretty detailed explanation of a normal trip and some of the unexpected things that can occur. On one trip Santa had two six week old babies literally thrust into his arms whilst standing on a moving train by a parent anxious to take a photograph. Mike told me that Santa was extremely concerned and could not wait to hand the babies back in case the train lurched and he lost his balance.

Unfortunately occasionally children like to pull Santa's luxurious beard. Santa has to grab the beard quickly because as you can imagine having his beard tugged hurts a lot. When not holding babies or protecting his beard, the enthusiasm and excitement of the children leads to a lot of very detailed questions that Santa has to be prepared to answer briefly and importantly totally correctly. For example a tired Santa was asked to name all of his reindeer. Of course occasionally a reindeer is not feeling very well so has to be substituted. Santa concentrates on checking the good and the naughty book and making sure the right presents are delivered to the right child. Luckily Rudolf has some managerial training so he takes care of all the other reindeer so that Santa can concentrate on his tasks. I feel that Santa is very lucky to have such a quick wit and such a trustworthy Rudolf!

Another child asked where his sleigh was. Well of course Santa lands his sleigh on the roof of the train so that the elves do not have to move the sacks of presents too far. The train is on a timetable you know! Of course the reindeer have to fly off with the sleigh before the train starts because otherwise the reindeer could catch their antlers on the low bridges. Again Rudolf oversees this operation. You may just be able to see the sleigh on the rear coach in the picture through the clouds of steam.

Is Santa as jolly as he is reputed to be? Well, he is a happy fellow but he does have a sense of humour. Some children have not quite grasped some economic realities, so when they are asked “What would you like for Christmas?” quite a selection can follow. A cheery “Well, just put it on the list and we’ll sort it” can cause a flicker of uncertainty on the faces of some parents until it is tempered with “But, I always read the long lists last and it is hard to remember everything on a long list. I have a better chance of remembering what is on a short list”. Apart from being jolly Santa is also wise.



**GREAT CENTRAL RAILWAY**  
LOUGHBOROUGH, LEICESTERSHIRE



Unfortunately Mike had to get to work but I did have a few seconds to say hello to Santa. Apparently I am still in the naughty book but maybe next year.... Santa did agree to pose for a photograph though!



## Afterthought

All the staff work extremely hard during the Christmas period. I love the idea of combining unfamiliar surroundings and a host of new experiences steam, a station, a train, the sounds and smells with visiting Santa.



It really worked for me and it is a fair few years since my children have been at the right age. I will be taking grandchildren though hopefully not for a few years yet, especially as Santa looked very smart in his new suit. There are a few seats available for this year but you will have to be quick.

# SEE CHASE & SKYE FROM PAW PATROL

GREAT CENTRAL RAILWAY LEICESTERSHIRE

TUES 18<sup>TH</sup> TO THURS 20<sup>TH</sup>  
FEBRUARY 2020



nick jr.



**WE ARE PROUD TO INVITE  
SKYE FOR THE FIRST TIME!**

THE HEROIC PUPS WILL BE MAKING PERSONAL APPEARANCES  
AT LOUGHBOROUGH AT THE FOLLOWING TIMES:

**CHASE: 11AM, 12PM, 1PM, 2PM & 3PM**

**SKYE: 11.30AM, 12.30PM, 1.30PM, 2.30PM & 3.30PM**



© 2019 NICK JR. ENTERTAINMENT, INC. ALL RIGHTS RESERVED.

Join in every day on Nick Jr.  
[nickjr.co.uk](http://nickjr.co.uk)

FACE PAINTING • MINI FUNFAIR • RIDE ON A STEAM TRAIN  
YOU CAN START YOUR JOURNEY AT ANY OF OUR FOUR STATIONS

**£38** FOR A FAMILY  
OF 5 (2A+3C)

**BOOK RAILWAY TICKETS ONLINE** [WWW.GCRAILWAY.CO.UK](http://WWW.GCRAILWAY.CO.UK)



@GCRGreat



@GCRofficial

Enquiries: 01509 632323

All tickets include unlimited rail travel and entertainment, except the fun fair rides and face painting. Platform only and short hop tickets are not available.

# Lightweight Scenery



## From EDM Models

When I were a lad (too long ago) it was typical to build scenery using Modroc or plaster bandage. You ended up with a beautifully contoured layout but it weighed a ton and was prone to cracking and chipping to the extent that it was recommended in numerous articles that you added brown poster paint to the mix so that if it did chip it didn't show starkly white.



It doesn't have to be like that! Some 25 years ago a friend built a lightweight layout on an ironing board and then spent the weekend extolling the virtues of this lightweight scenery material called Sculptamold demonstrating its toughness by bashing a sample on a table

edge all weekend. It took until Sunday afternoon to break it.

I've stocked Sculptamold ever since.

Recently, it became apparent that whilst I thought everyone knew about the stuff it was actually a bit of a secret. So, what is it?

It's a plaster like powder with fibres in it for strength but its cellulose based – basically posh papier mache – but with a water activated binding agent in it.

You mix it up with water and you can make a runny mix or a stiff and spoon it on to a frame and smooth is out with fingers and assorted spatulas. What it lacks as it comes is the 'bandage' element.

## Top Tip

Add the bandage element with net curtain material. Ask your local charity shops if they have any old net curtains. It'll probably be in the scrap rag bin. I am told that they get loads donated in house clearances but it's rarely saleable.

Make a card skeleton of your hillside. Add screwed up newspaper between the skeleton as temporary supports Cut the net into strips,



dunk it in a sloppy mix of Sculptamold and work it a bit to get the net impregnated with the goo (get your fingers in it). Lay the strips over your former overlapping several layers. Massage it with your fingers to merge it all and smooth it out to get the shape you want, add more layers of dollop more Sculptamold on to it and shape it.

Dryer mixes can be moulded into rock shapes and then stuck in place with sloppier mixes. It also works into rock moulds intended for plaster.

Let all dry and you have a lightweight and rock hard shell that that you can even remove the scrunched up paper from beneath so your hill can be hollow

*This example has been to a few too many shows over 20+ years and is looking a but tired but it shows what can be done*

---

## **First 3D Printed Wagon to be Discontinued**

Earlier this year we got our new production quality 3D printer and released this Snailbeech Railway inspired hopper wagon. It sells in a pack of 3, comes with turned metal RP25 profile wheels, genuine Ka-dee couplers. The hoppers come unpainted.

After six months of printing over a hundred of these

wagons the time has come to discontinue them. We've learnt a lot about the CAD for printing, the printing, and the printer, as well as the post processing and packing work. Its time to retire these and, eventually, replace them with items utilising the lessons learnt.

They were selling for £55 for a pack of three but whilst stocks last they're now £45

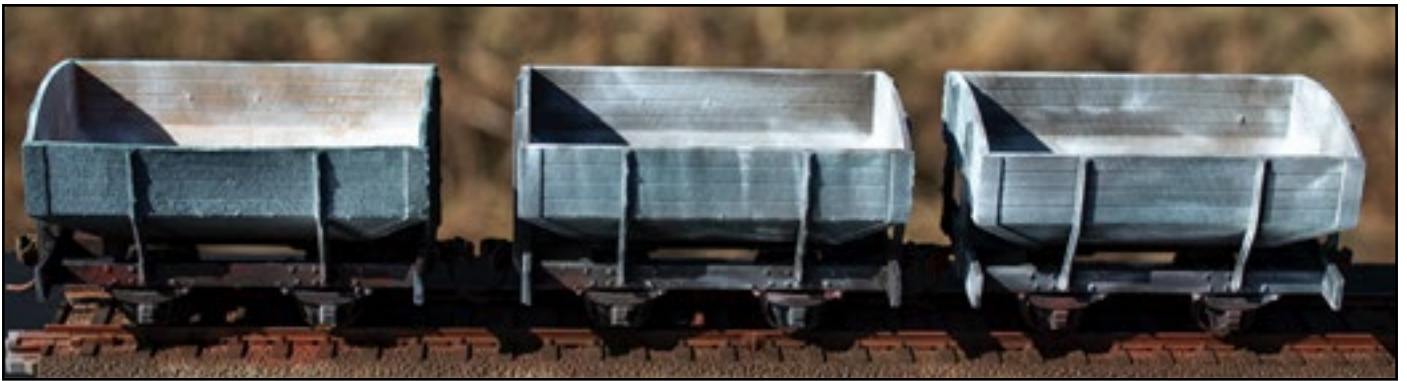



RAILS OF SHEFFIELD

railsofsheffield.com

Corporate member of



**HORNBY** HORNBY 2018 NEW RANGE! **HORNBY**

R2607TTS	NER L36 CLASS 0-6-0 473 MAUDE WITH TTS SOUND	£327.50
R2607TTS	BR LORD NELSON CLASS 4-6-0 LOCOMOTIVE 20650 'LORD NELSON' WITH TTS SOUND	£148.50
R2618	NER A4 CLASS 4-6-2 4466 MALLARD - LIMITED EDITION ANNIVERSARY PACK	£382.50
R2615	POCKETT WORKS LIVERY NO.580/1833 0-4-0ST	£79.50
R2617	BR, REBUILT MERCHANT NAVY CLASS, 4-6-0, 28028 'ELDER DEMPSTER LINE'	£338.50
R2616	BR, REBUILT BATTLE OF BRITAIN CLASS, 4-6-2, 34050 'ROYAL OBSERVER CORPS'	£338.50
R2619	BR CASTLE CLASS 4-6-0 5078 'MERRIVENNY CASTLE'	£329.50
R2621	NER L26 CLASS 0-6-0 STEAM LOCOMOTIVE 722	£107.50
R2622	BR, J26 CLASS 'HAIG' 0-6-0 STEAM LOCOMOTIVE 67631	£107.50
R2623	NER 'QUEEN ELIZABETH' PRINCESS CORONATION CLASS 4-6-2 STEAM LOCOMOTIVE 9221	£148.50
R2630	NER L44 CLASS 'WOODCOCK' 4-6-2 STEAM LOCOMOTIVE 4483	£338.50
R2631	BR H CLASS 0-4-4T LOCOMOTIVE 3165	£98.50
R2632	BR 'EAST ASIATIC COMPANY' MERCHANT NAVY CLASS 4-6-2 STEAM LOCOMOTIVE 35036	£337.50
R2634	BR, 'SIR FRANCIS DRAKE' LORD NELSON CLASS 4-6-0 STEAM LOCOMOTIVE 381	£338.50
R2635	BR, 'LORD RODNEY' LORD NELSON CLASS 4-6-0 STEAM LOCOMOTIVE 35663	£329.50
R2638	BR, 'BIDIPONDY' WEST COUNTRY CLASS 4-6-2 STEAM LOCOMOTIVE 34019	£342.50

R2639	NER 'KING GEORGE V' PRINCESS CORONATION CLASS 4-6-2 STEAM LOCOMOTIVE 9244	£148.50
R2677	NER 'DUCHESS OF HAMILTON' PRINCESS CORONATION CLASS 4-6-2 STEAM LOCOMOTIVE 9238	£148.50
R2680	CLASS 67 6708 'ROBERT BURNS' BR RAIL BLUE (CROSS ARM PANTOGRAPH)	£129.50
R2682	CLASS 67 016 'KING ARTHUR' BR INTERCITY SWALLOW LOCO (HIGH SPEED PANTOGRAPH)	£129.50
R2687TTS	BR INTERCITY, CLASS 43 HST, 'VALENTA' POWERED TRAIN PACK WITH TTS SOUND	£229.50
R2686	PULLMAN, 8-BEL 'BRIGHTON BELLE' TRAIN PACK	£134.50
R4671	MATCHING COACH PACK 8-BEL 'BRIGHTON BELLE' COACH PACK	£137.50
R2689	GWR, 1EP BI-MODE CLASS 66/70 'QUEEN ELIZABETH II' & 'QUEEN VICTORIA' TRAIN PACK	£229.50
R4670	MATCHING COACH PACK GWR, 1EP BI-MODE CLASS 66/70 COACH PACK	£137.50
R4616	SR, MAUNSELL KITCHEN/DINING FIRST, 37663	£38.50
R4617	BR, MAUNSELL KITCHEN/DINING FIRST, 37645	£38.50
R2688	VERGIN TRAINS CLASS 67 018 'SIR WINSTON CHURCHILL' 80-80 LOCOMOTIVE	£138.50
R2689	COLAS RAIL FREIGHT CLASS 67 023 80-80 DIESEL LOCOMOTIVE	£123.50
R2692	GWR GREEN CLASS 55 300 DMEL LOCOMOTIVE	£94.50
R2687TTS	VENT VAN WITH TTS SOUND	£32.50

SEE OUR WEBSITE FOR FULL LISTINGS  
EXCLUSIVE SPECIAL OFFERS & BUNDLE DEALS!  
[www.railsofsheffield.com](http://www.railsofsheffield.com)

PRICE & AVAILABILITY IN STORE AND ONLINE ITEMS: The prices advertised on Railsof Sheffield website will be the price charged at the time of the order being processed. The supplier may at times be a 20% in the event of a sale and will be indicated over to the order being processed and given the option to accept the normal price or apply the sale.

PLEASE NOTE: All items currently in stock are dispatched immediately. For stocking references will be dispatched immediately upon release. If your order contains both current items and forthcoming references these will be dispatched separately and subject to separate delivery charges.

All popular  
Manufacturers

ALSO STOCKED AT BARGAIN PRICES!



**NEW** NOW STOCKING **Revolution N** SEE OUR WEBSITE FOR FULL LISTINGS

STATION OFFICE: 21-29 CHESTERFIELD ROAD, SHEFFIELD S1 2JF. Open 10am to 6pm, 7 days a week. Delivery to door within 2 days of dispatch including Saturday. (This is not a guaranteed service and parcels can take longer to reach.)  
STATION, 21-29 CHESTERFIELD ROAD, SHEFFIELD S1 2JF. Open 10am to 6pm, 7 days a week. Delivery to door within 2 days of dispatch including Saturday. (This is not a guaranteed service and parcels can take longer to reach.)  
STATION, 21-29 CHESTERFIELD ROAD, SHEFFIELD S1 2JF. Open 10am to 6pm, 7 days a week. Delivery to door within 2 days of dispatch including Saturday. (This is not a guaranteed service and parcels can take longer to reach.)

PLEASE NOTE: ALL ITEMS CURRENTLY IN STOCK ARE DISPATCHED IMMEDIATELY. For stocking references will be dispatched immediately upon release. If your order contains both current items and forthcoming references these will be dispatched separately and subject to separate delivery charges.