

International Edition

Free,
electronic magazine
for railroad enthusiasts
in the scale 1:220
and Prototype

www.trainini.eu

Published monthly
no guarantee

ISSN 2512-8035

Trainini

German Magazine for Z Gauge



90 years of Rheingold

Digital walking attempts
Fair report from Cologne

Introduction

Dear Readers,

the Advent season is already over again, tomorrow begins Christmas. We have long been heading for the high point of the season marked by hobby work.

I'm sure we won't run out of Zetties' wishes. Even apart from the mundane and political events, in which peace, harmony and a wholesome livelihood unfortunately remain unfulfilled for many people, we have one or the other thing on our hearts.



Holger Späing
Editor-in-chief

My editorial colleagues and I wish you all a Merry and Blessed Christmas, that you will find happiness, keep your health and have a Happy New Year!

When the Christmas business is over, we will continue to work busy. We will first discuss and vote on the new releases for 2019. Many aspects have to be taken into consideration if we want to make a judgement that is groundbreaking, advertising and leading for the manufacturers of what we enjoy again and again.

Shortly afterwards, we will be informed about the innovations planned for 2019, which are to be included in our reporting. In the interest of all Zetties, we can certainly do a lot of lobbying for the future. You, our loyal readers, put us in a position to do this by constantly seeking dialogue with us and providing us with suggestions. We would also like to express our sincere thanks for this today!

And so I hope that once again we have compiled exciting topics and reports for you, which will provide you with reading pleasure and inspiration at the same time, but also encourage you to continue the dialogue with us, to express your opinions and wishes, but also to present the many hard work that makes our hobby so varied.

Until the end we have kept a look into the eventful history of the Rheingold train. Unfortunately, the announced novelties didn't arrive in time, but we can certainly stir up anticipation! We also got caught up in the action and so, with 18 505, we created a replica of a locomotive that has an equally interesting past and itself belongs to the series that was proud to haul the Rheingold.

The first digital experiences that Dirk Kuhlmann reports on today are also a consequence of the series that Andreas Hagendorf led us through this year. Here the spark has clearly jumped over in the editorial department as well. Input from our readers confirms that our editor is not alone in this and I cannot absolve myself either.

However, the last quarter of an even year always includes the International Model Railway Exhibition in Cologne. This year we particularly liked it, we see the fair back on the road to success. Read in this issue why we are drawing this conclusion.

Sin-Z-erely,

Holger Späing

Editorial

Introduction 2

Model

Queen of the steam locomotives..... 4

Prototype

The legend of the Rheingold.....20

Design

Currently no items

Technology

Practical beginner experiences35

Literature (not translated - only in German)

Photo collage of the Old Master40

The car standard work 2.042

News

A biennial highlight44

Zetties and Trainini in Dialogue.....60

Imprint.....72

We thank the Eisenbahnstiftung, Ulrich Budde and Detlef Klein for their photo support.

Date of publication of the German language version of this issue: 24 December 2018

Cover photo:

Here, the photographer captured 18 505 of the Deutsche Reichsbahn at the beginning of the thirties with the FFD 101 "Rheingold". With the German luxury train it is on its way downstream on the Rhine and will soon reach its next destination, Köln Main Station, to continue on to the Netherlands.

The ex-Minden 18 505 of the DB Queen of the steam locomotives

2018 is also an anniversary year for the Bavarian S 3/6. Its history goes back 110 years. With a procurement period of 22 years in a little changed form, it has an almost unique history. Historians have praised it as probably the best German steam locomotive construction in terms of architecture, thermodynamics and operation. We therefore wanted to pay tribute to the famous locomotive of the Rheingold with the model.

At the end of 2018 not only the Rheingold celebrates a round anniversary. Its most popular locomotive, the former Bavarian S 3/6, is also one of this year's jubilees. It appeared on stage for the first time in 1908 and thus became 110 years old this year.

During her service, she was never just some express steam locomotive. It was considered to be balanced, efficient and elegant. Her lovers therefore called her the queen of steam locomotives, which only underlines her elegant appearance.



Built by Maffei in 1924 and still put in service as "3706", 18 505 outlived her sisters as a locomotive at the locomotive testing facility in Minden (Westfalia). It was not until 20 May 1967 that it was taken out of service there. Photo: Wolfgang Bügel / Eisenbahnstiftung

By 1930 a total of 159 machines had been purchased, 89 (series a to i) from the K.Bay.Sts.B. and 70 (series k to o) from the Deutsche Reichsbahn. The first series still had a streamlined cab, which



Old master Bellingrod also immortalized the once best-known S 3/6 on celluloid. On 8 June 1957 18 505 ran with a measuring train to the Fulda embankment near Friedlos between Bad Hersfeld and Bebra. Photo: Carl Bellingrod / Eisenbahnstiftung

corresponded to the ideas of aerodynamics at that time. Almost all S 3/6 had 1,870 mm large drive and clutch wheels.



After its retirement, the locomotive could be seen at many exhibitions in the seventies, such as here at the steam farewell party in Stolberg on 2 April 1976. Photo: Wolfgang Bügel / Eisenbahnstiftung

The only exceptions were the 18 locomotives of the series d and e built in 1912. These “high-heeled” locomotives were equipped with wheels of a diameter of 2,000 mm in order to be able to run at a maximum speed of 120 km/h over longer distances.

In contrast to the previous and subsequent series of the K.Bay.Sts.B., they did not receive any wind blades, but a newly developed, larger tender of the type bay 2'2 T 32.5. The wind blades were finally dispensed with for the locomotives subsequently procured by the Reichsbahn.

The representatives of the S 3/6 ordered by the DRG's Bavarian group administration can be divided into two groups: The first with the series k, to which also the 18 505 belongs, 30 copies were built between 1923 and 1924. Since the renumbering system had not yet come into force, they still came into service with the Bavarian company numbers 3680 to 3709.

In 1926 they were renumbered 18 479 to 18 508. In terms of thermodynamics (at an unchanged boiler pressure of 15 bar) and economy, they already represented a further development which, as a tried and tested regional railway type, was intended to close gaps in the stock by means of reparations levies.



For 18 505 there is no evidence of any use in front of the Rheingold, but this simulated shunting trip in front of the historic Rheingold in Niedermendig still looks deceptively real. In fact, on 9 May 1975, 044 508-0 pushes at the other end. Photo: Wolfgang Bügel / Eisenbahnstiftung

In addition to other details, they differed from their predecessor series primarily due to the larger superheater (enlarged from 50 to 62 m²) and the driver's cab with bevelled side walls at the top, as was to become common in the later standard locomotives in a similar form.

They were equipped with the large tender bay 2'2 T 27.4. The axle loading had increased from 16 to 17 tons compared to the machines of the first years of construction due to the reinforced construction, but was still considerably lower than that of a class 01. This advantage finally led to the procurement of further series, the delivery of which was delayed until 1931.

View into the history of 18 505

Since we have chosen the 18 505 as the model for our model conversion, we would also like to take a brief look at its operating history. In principle, it is not only suitable for use before the Rheingold, but also has a special feature with its service at the Minden Research Station.

The locomotive was built in 1924 by Krauss-Maffei (Munich) with the factory number 5555. It was delivered to the Reichsbahn with the Bavarian company number 3706 on 2 May 1924; the final acceptance took place exactly two weeks later.

It was then assigned to Bw Nürnberg Hbf, where it was operated from 20 May 1924 to 9 April 1947. She also returned here on August 30, 1947, after a reconditioning. There she continued to serve until September 3, 1953, before moving to the Lindau district on 23 October of the same year. There she remained only a little more than one year until January 9, 1955.

At that time the class 184-5 had long been on the Bundesbahn's 1 retirement list. In view of a quite high stock of high-quality express steam locomotives, the oldest representatives of this class were foreseen as dispensable. The specimens of the younger series had a somewhat longer grace period.

18 505 would outlive all others in service. Its fate led it to be used as a brake locomotive to the LVA Minden, where it was coupled with a large unit tender 2'3 T 38.5. There it lived to 20 May 1967 despite its position until the formal re-designation as 018 505-8 per 1 January 1968.



From 17 March 1955 to 20 May 1967 18 505 worked for the Lokversuchsanstalt (Locomotive test facility) in Minden. In 1960, on the occasion of the 125th anniversary of the German railways, it was temporarily coupled with the tender of the 18 483, painted in the colours of the regional railways and equipped without smoke deflectors with the (false) Bavarian company number 3642. When it was photographed on 6 June 1968, it had not yet been taken out of service. Photo: Will A. Reed / Eisenbahnstiftung

When the 125th anniversary of the German railways was celebrated in 1960, it took part in the official celebrations. It was temporarily coupled with the tender 2'2 T 27.4 bay of the 18 483. Painted in the colours of the regional railways and provided with the company number 3642, which did not match her, she took part in various exhibitions without smoke deflectors.

At the beginning of 1969 the steam locomotive was transferred to the decommissioned Bw Treuchtlingen (decommissioned only on 10 July 1969) and stored there in the locomotive shed. Via Bamberg she finally came to Neuenmarkt-Wirsberg.

In 1972 the DGEG took over the 18 505 as a loan from the DB and transferred it to the railway museum Neustadt/Weinstraße, where it can still be admired today. However, it did not become the property of the DGEG until March 1977.



This photograph of the museum locomotive 18 505, taken during a stopover on the right bank of the Rhine, probably Kaub, dates from the summer/early autumn of 1992. This external condition was the free model for our model conversion. Photo: Detlef Klein

Only at its final location could it again be coupled with a tender 2'2 T 31.7 bay, which came from 18 612 and was suitable for it. In this correct composition she was to be seen among other things 1976 at the big steam locomotive farewell party of the BD Köln (Cologne) in Stolberg.

In 1978 it could be photographed, unfortunately in very bad weather, in front of the museum train of the FEK (Freundeskreis Eisenbahn Köln) as part of the anniversary of "50 years of Rheingold" in Köln Hauptbahnhof (Cologne Central Station). But there could be no more beautiful scenery than the historical set from 1928 in front of the Cologne Cathedral and the hall of the main station.

In 1985 18 505 took part in the vehicle show in Bochum-Dahlhausen to mark the 150th anniversary of the railway in Germany. Still today, it is in a good condition, but no longer travels through the country, as was common in the past.

Conversion for Märklin

For many years Westmodel offered a brass cast conversion kit to convert the locomotive and tender from Märklin's S 3/6 to class 185. It consisted of a board attachment for the tender (art. no. 40035) and a cab without streamlining (40034). We also had recourse to a remainder that consisted only of the cast part for the locomotive.

The donor model was a Märklin model 8893 of the first version with bare rods, which should cause us problems. All Göppingen replicas of the later class 184 are coupled with a matching tender 2'2 T 27.4 bay, which in this case was wrongly labelled as 2'2' T 26.4 bay of the first construction lot.

According to reports in the technical literature, the tender design with the front bogie and two following rigid axles at 27.4 m³ water capacity was at least partially coupled with the class 185 up to the company number 18 508.



This is how our 18 505 is on its way after its conversion. The tender 2'2 T 27.4 bay is a compromise, but in the first years of service it was actually coupled with steam locomotives of this subclass according to the literature.

We have not yet found any reliable picture evidence for this, but this seems to us to be largely ruled out for the period of service at the Bundesbahn anyway. Nevertheless, we only considered a DB machine for which the necessary compromises were to be kept as small as possible.

Due to the lack of legibility from a normal viewing distance, this meant that instead of a “biscuit”, a written out Bundesbahn sign on the driver's cab would appear on the screen, so that the machine could sometimes be used as a DRG copy (with electrical lighting). This enabled a case-by-case use even in front of the Rheingold.



The tender received a coal box elevation and a higher coal mountain with the help of polystyrene filler (picture above). Before spreading the real coal the coal load and the top were painted black, and the lanterns were painted white (picture below).

But then we had to come to terms with the not quite correct tender. It lacked the stiffening side struts on the coal box and also the position of the water inlet did not fit exactly.

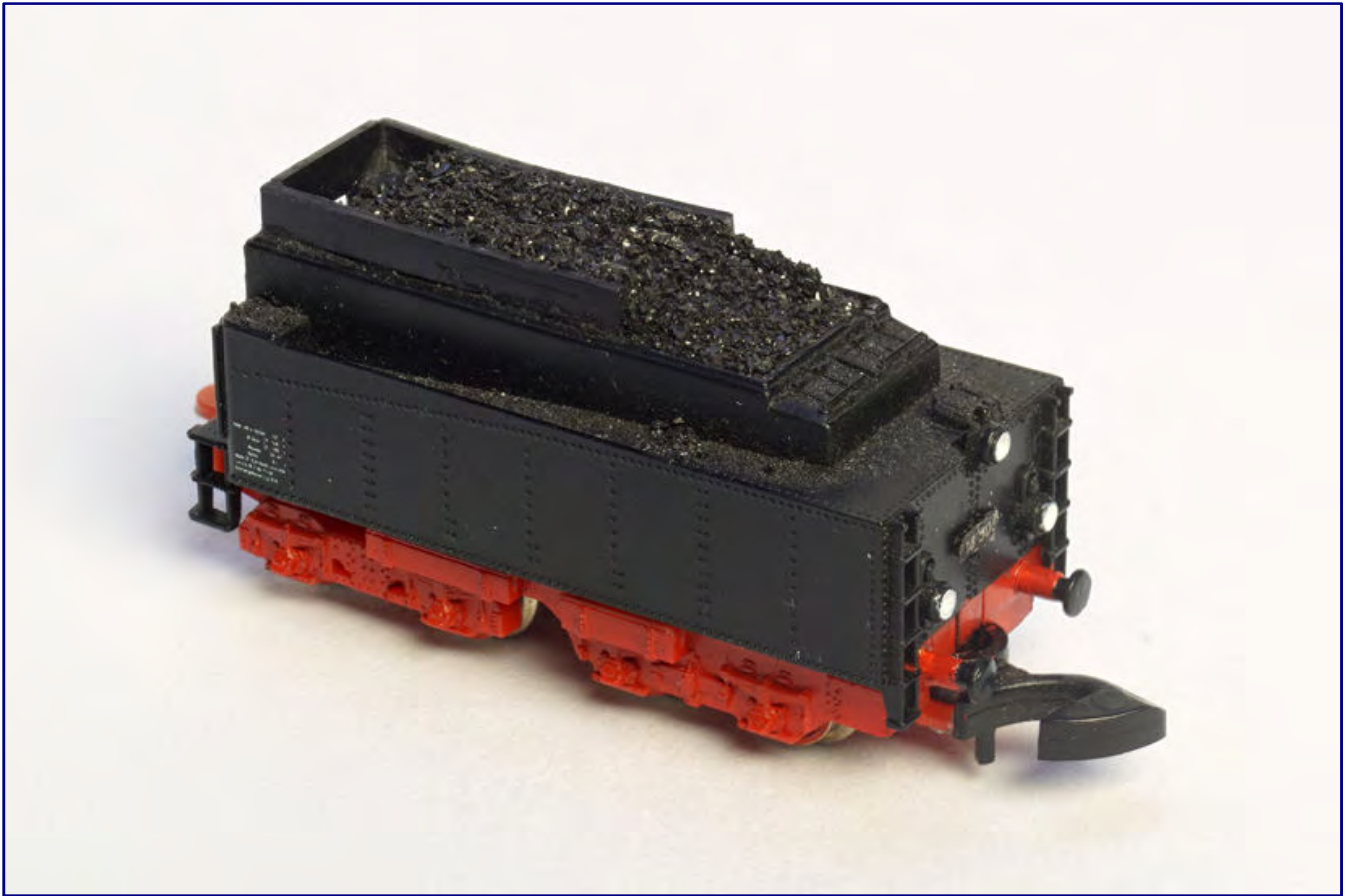

The tender has already been completed, at least once, with a real coal layer from Jeweha Modelbouw and a new company number plate from Kuswa. Then it is a match to the locomotive itself.

In addition, the prototype had two bogies, which was also noticeable due to different wheelbases.

Our research finally led us to the 18 505 with its special history, which justified both the DRG and DB service period, as well as an era with its function as a museum locomotive. Only with it did the coupled Märklin tender appear credible in most respects.

However, with the restrictions described above, the model can at least be considered to have a regular service life in planned operation between 1947 and 1955 at Bw Nürnberg Hbf and Lindau as well as a second career as an exhibition or museum locomotive. This makes the chosen model unique in any case.

But until then there were still some conversion work to do, which we would now like to describe. It was only completed relatively quickly at the tender, which only required a (welded) coal box elevation according to the model. Because we had no access to the cast part from Westmodel, we had to make it ourselves.

We could fall back on remains of a bow of black polystyrene (PS) from Lütke Modellbau, from which we cut the three required strips along the steel ruler with a scraper. With Uhu Plast Spezial we glued them to the coal box and joined them together at the corners.

After curing, it was possible to raise the coal pile inside the tender and at the same time stabilize it: we made a suitable filling compound from the grey residue of the injection moulding.

The PS cut into small pieces could be dissolved into a paste in a glass with the aid of acetone. After it had been spread on the tender, it was urgent because the solvent quickly evaporated again. With our plastic putty we filled the front part of the coal box up to its side edges and modelled the cone of debris to the rear as well as descending to the extraction point.

In the dried condition followed a matt black lacquer coating with enamel paint from Revell, colour number 8. She also distributed unwanted plastic shine from the carbon box replica. This was followed by a real coal layer of "Hard coal extra fine" by Jeweha-Modelbouw (0400.5), which was placed upon a glue bed.

The three unlit locomotive lanterns also deserved a little post-processing. The appearance of the ceramic reflectors is closer to white than the silver-coloured prints ex-works. A fine round brush and silk matt RAL 9003 signal white from Oesling Modellbau helped here.

In order to give the impression of the lantern discs, we dab on a glossy clear varnish (Revell Aqua Color 36101) after drying. The result was much more convincing than the earlier factory versions. Märklin has also long since recognized this in its recent production.



Here you can see the basic model 8893 and the untreated brass casting of Westmodel before the beginning of the reconstruction. The polystyrene remains are intended for the conversion of the tender.

But the chassis also underwent some adjustments. The plastic shining plastic was overpainted matt in addition. RAL 3000 fire red from Oesling Modellbau was the colour of choice here, from which the wheelsets of the model also benefited. We sanded the wheel tires and primed the metal surfaces with neutral yellow PU primer from Badger (SNR-206) so that they could be held there.

The buffers were exchanged by Bahls Modellisenbahnen for correct size specimens made of cast brass and also color matched. As in the prototype, these new models also show a curved (right) and flat buffer plate (left). The new signs for the 18 505 had already been delivered to Kuswa early. At the tender we attached one of the nickel silver etched parts with the company number in raised numbers with the help of Uhu Alleskleber (all-purpose glue) Super Strong & Safe.

Metamorphosis of the locomotive

There was much more to be done on the housing of the steam locomotive. In order to install the brass casting for the driver's cab with a straight end wall and side walls retracted at the top, the old one had to be replaced. The cut on the die-cast housing was made exactly in the area of the first boiler ring, i.e. directly in front of the standing boiler.

After the sprue channel was removed from Westmodel's brass replacement part, fitting tests could begin. It turned out that hardly any grinding work was necessary. Before the gluing process, however, we put our hands on it again: On the roof of the driver's cab there was a ventilation duct which was used with the original kerosene interior lighting.



The streamlined cab is cut off; the brass replacement part is already waiting to be finished: The chimney of the petroleum lamp behind the ventilation box has been removed. Märklin's zinc die-cast block is prepared for subsequent bonding by drilling holes, but a temporary holder must first be built that can hold both parts securely in place until the two-component adhesive has set.

Since our model was electrically illuminated, it had to disappear. Grinding it off with a key file was no problem. A challenge, however, was the subsequent creation of sufficiently dimensioned adhesive surfaces for the boiler, because the Märklin housing could not be soldered.

Epoxy and acrylic resin compounds provide the best results when bonding metals. The decision to use Pattex Stabilit Express was therefore made quickly. It is recommended to increase the adhesive surface and not to leave the flat contact surface of both parts for a permanently firm hold.

Unfortunately, there was no alternative for the Westmodel driver's cabin. At best, the attachment of a thin polystyrene strip in the inner curve of the boiler would have been an option, if the housing could have been placed on the chassis block in this way.

The opposite side of the Märklin boiler was lighter. With pencil blocks and a fine HSS twist drill some holes could be driven in, which were later filled with the adhesive resin.

Before it was so far, however, still a suitable underlay remained to be constructed, on which both housing parts could be attached at the correct height and were tilt proof.

It had to be dimensioned in such a way that the adhesive could not form a permanent bond with it and harden in peace without the two adhesive halves shifting. A brass block, small PS parts and adhesive film were used.



With Pattex Stabilit Express the zinc die casting and the brass casting are permanently joined. The adhesive is first filled deep into the boreholes before the adhesive seam between the two halves follows.

The acrylic resin mixed from two components was finally carefully painted on both halves. Then they could be pressed together on the holder. Resin escaping upwards didn't bother us much for the time being, because after setting it was much easier to remove it with the craft knife. Possible gaps could also be effectively filled in this way.

Inside, the self-made support kept the glue in check. What might turn out to be annoying could be milled away if necessary. And so we were soon able to move on to the painting work.



The glass inserts of the front side windows of the driver's cab were also made from a moulded part. Contacta Clear from Revell proved to be a suitable adhesive because it dried invisibly.

We glued the front part of the case with the proven Tamiya cover to avoid risking any colour on the lantern in front of the smoke chamber door.

After degreasing the surfaces which required painting, a black primer was applied from the spray can, which still came from Model-mates. It proved to be an excellent match for the Märklin paint.

This step was completed with the fire-red setting down of the lower edge of the circulating and driver's cab. With this combination, we also painted the surface preheaters, which lay transversely between the dome axles, red.

The results gave us confidence and so we decided to give the front side windows in the driver's cab a window as well. They were made of polystyrene cut to size of about

2.3 x 2.5 mm (w x h). We could fall back here on moulded leftover parts, or otherwise there are suitable plates also with Evergreen (distributed by Faller).



We glued the new silver signs with Eagle Owl All Purpose Adhesive Super Strong & Safe. A tiny drop is enough to hold a sign. Here the type plate (see arrowhead) is waiting to be attached to the driver's cab.

They were carefully fitted in and carefully pressed into place. So that they could not fall out during operation, it seemed to us that it was a good idea to secure them with glue. However, only materials that could run well into the small cracks due to their viscosity, adhere there thanks to capillary action and cure themselves to complete transparency were considered.



The view of the finished driver's cab is quite satisfying. The black wheels can also be clearly seen, the raised structures of which were then painted fire red.

We found what we were looking for at Revell: Contacta Clear is an adhesive varnish, similar to a water-based clear varnish, which had all the required properties.

It was actually intended to connect two PS transparent parts to one another. But also for connecting metal and without compression it proved its strengths.

With the installation of new nickel silver shields, the case work was also completed. It received 18 505 company numbers on the smoke chamber and the driver's cabin

walls, two lateral lettering "Deutsche Bundesbahn" (German Federal Railroad) and one sign at each back

corner with the generic designation S 36.18. This is at least somewhat reminiscent of its former Länderbahn designation.

The fine detailing of the driving gears caused headaches. Bahls Modelleisenbahnen offered an excellent and fully movable detail control for the Bavarian S 3/6, but it did not seem appropriate from a cost point of view. In view of the desire for a DB machine of the 185 series, which became known above all as a non-operational exhibition locomotive, and the compromises already described, other approaches were required.



With parts of the linkage of a Märklin 03 series, a Bahls detail control for the same model and the control carrier, the new fully movable linkage for the 18⁴⁻⁵ series the model could finally be completed externally.

Since Michael Bahls fulfils almost every customer requirement, a solution was found here as well, but separate versions are added soon. The work on the chassis began with colour work, some of which we had already carried out on the tender.

This meant first of all removing the bright nickel-plated Märklin linkage in order to get free access to the wheels. Next, all wheel tires on the locomotive were sanded to get a better primer for the paint.

All wheels were then fogged with matt black primer to make the spaces between the spokes almost invisible. The wheel tires were also primed before they could be coated fire red with fine brush work together with the spokes and wheel hubs. This made the wheels appear much finer and more filigree.

Unfortunately, the solution in the area of the linkage was not possible without standard Märklin parts. The blank and not red parts of the early edition of our basic model were out of the question, because they would have affected the intended result too much.

As a result, a suitable Märklin model of the 03 series, which is based on the same chassis, became a further donor for our 18 505. The coupling rods could be used without any substantial modifications, only the crosshead had to be removed from the driving rod and the interface had to be sanded.

The reason for this perhaps unusual step was that Bahls model railways did not have any suitable etched parts (anymore), because in the meantime almost only fully movable controls are in demand. The class 18⁴⁻⁵ was previously equipped by Michael Bahls with the parts of the class 03 unit locomotive.



Also technically the converted model was still upgraded: The old plug-in base lamp had to give way to an LED insert with yellow light developed by our reader Hans-Jürgen Zimmermann.

At the time of our implementation, however, only the cast parts with counter crank, swing arm, control unit, crosshead and leading lever were in stock. These were now combined with the Märklin parts. In order to adapt the look of the locomotive to the original, the new etched part of the control carrier was used, which was simply glued on and painted.

This solution was almost no longer a compromise and fully met our expectations. This set-up action was completed with the cast brass buffers, which were also attached to the tender, as well as a clutch replica. The prototype locomotive did not have a ladder on the buffer beam.

For the brake replica on the bogie, Michael Bahls could use his existing etched parts unchanged. Externally, our demonstration steam locomotive was now optimally equipped, and we were also satisfied with the running characteristics of the three-pole engine.

However, the top light of the model still had to be brought technically up to date. The incandescent lamp was allowed to retire and was to be replaced by modern light emitting diodes. We found a perfect solution in the circle of our readers, as we have often noticed.

Hans-Jürgen Zimmermann from Düsseldorf had already developed his own LED modules some years ago with similar intentions, with which he could retrofit his models. He designed them in warm white and

yellow to adapt their appearance to different eras and equipment. Also, he was able to accommodate switching red tail lights into the modules.



Now that all the work on the model has been completed, 18,505 are allowed to test drive it on the layout - in keeping with the style with the Rheingold on the hook, to which it has often been connected as a museum machine.

And so we made use of one of his samples, just as we did for the conversion of 03 1049 (see issue 9/2015). Since Märklin's model of the 18⁴ series has a third top light, in contrast to the previous model, a module with three instead of two SMD light emitting diodes was required. We decided to go for the yellow version again.

If you are interested in these modules, please contact Hans-Jürgen Zimmermann via the editorial office. He has structured and numbered his building blocks in order to be able to assign the appropriate Märklin models to each base variant. Within the scope of a professional exchange and mutual help, he also passes on his knowledge and skills to other hobby friends on a private basis.

Our conclusion in any case is complete satisfaction: With justifiable effort and a lot of fun, a model, that had previously received little personal attention, has become a beautiful model that will certainly not only leave a good impression in photographs.

Manufacturer of rolling stock:

<http://www.bahls-modelleisenbahnen.de>
<https://www.maerklin.de>
<http://www.modscholz.de>

Materials, tools and labelling:

<http://www.jeweha-modelbouw.be>
<https://www.kuswa.de>
<http://www.oesling-modellbau.com>
<http://www.pattex.de>
<https://www.revell.de>
<https://www.tamiya.de>
<https://www.uhu.de/de>

Contact Hans-Jürgen Zimmermann:

Communication via the Editorial Office

Ihre Bildsammlung braucht einen sicheren Hort!

Unsere Aufgaben:

Bildsammlungen:

- **bewahren**
- **bewerten**
- **veröffentlichen**

Eisenbahnprojekte:

- **fördern**
- **initieren**

Unsere Garantien:

- + **personenunabhängig**
- + **sicher**
- + **gemeinnützig**
- + **steuerlich privilegiert.**

*Sie möchten
eine Sammlung
der Nachwelt
erhalten?*

0173 / 295 19 21

Rufen Sie uns einfach an!

*Sie möchten
unsere Arbeit
unterstützen?*

Spendenkonto:
Sparda-Bank West
Kto.: 579 484
BLZ: 330 605 92

EISENBAHNSTIFTUNG

JOACHIM SCHMIDT



www.eisenbahnstiftung.de

90 years of the German Luxury Train **The legend of the Rheingold**

The Rheingold is probably Germany's most famous train. Although it has been in the past for over thirty years, it continues to exist like a legend. At the end of this year, we look back on the ninetieth anniversary of its start. And so the focus of the model railroaders was on him again. This gives rise to a review of the model and also the prototype.

The origins of the German luxury train, which celebrates a round existence this year, go back to the supremacy of the International Sleeping Car Society (ISG) in Europe as well as to the consequences of the First World War.

In the German Empire, the intention had long existed to have sleeping and dining car services taken over by a German company. After all, the ISG had its legal seat in the territory of the former French enemy.

The concrete occasion was then the First World War. And so the Central European Sleeping Car and Dining Car Company were founded in Berlin on 24 November 1916. Most readers will be familiar with it under its abbreviation MITROPA.



In 1930 when 18 524 the FFD 102 "Rheingold" passed the Peternach block station near Boppard southwards, it already had electric lighting, but no smoke deflectors. From our current point of view, the main signal with the negative sign on the arm also appears unusual. Photo: DLA Darmstadt (Maey) / Eisenbahnstiftung

However, in view of the German defeat and the conditions of the Treaty of Versailles, their business did not go as expected. Many companies had only a brief period of activity until May 1919, when they were finally shut down. When long-distance traffic resumed, the ISG had an advantage and could maintain its dominant role.



Colour impressions from the operating time of the FFD 101/102 "Rheingold" can only be gained from models. For years Märklin sent the luxury train on its journey in the footsteps of H0 and Z with the class 184 including the streamlined cab, which is historically incorrect.

Meanwhile, the glorious Orient-Express operated by ISG made a detour around Germany for many years. The country lay in ruins in many ways. When the Deutsche Reichsbahn-Gesellschaft was founded and the galloping inflation was overcome, several years of upswing followed, which today are often referred to as the "golden twenties".

In times of growing prosperity, the DRG wanted to share in the success of the luxury trains operated by the ISG. The analyses of the business economists directed the focus of the railway mainly on solvent customers from Great Britain and Switzerland. A new train should therefore ideally connect these two countries and run across German territory.

The Reichsbahn looked for international connections, extended lines and developed modern passenger coaches and bogies. What it planned in concrete terms became clear in part when it announced the planning and ordering of 20 D-Zug coaches with special equipment. The small number of units did not indicate any known routes or train types.

At the international timetable conference in Prague from 18 to 22 October, the maps were revealed: Among the timetable requests was one for a daily connection between Amsterdam and Hoek van Holland in the north and Basel in the south. It was to be served by special Pullman-type cars.

This was the birth of the Rheingold, a new type of luxury train, the FD, which began service on 15 May 1928 and was operated by MITROPA. The name of the trains operating as FFD 101/102 was derived from the legend of the Nibelungen treasure sunk in the Rhine. Its standard covering consisted of two 1st and 2nd class cars each, including a dining car, as well as a shorter baggage car of the latest design.

His limitation to the 1st and 2nd class in the 4-class system still in existence at the start of operations is surprising, especially as the economic data were already declining again. In 1st class only 0.03 % of all DRG passengers travelled at that time!

However, this also clearly shows that rich travellers from abroad were increasingly courted and counted among the most important target group. The Reichsbahn also advertised strongly along the touristy interesting Rhine Valley, and the name of its flagship train already underlined this fact.



What a stark contrast the last epoch of the history of the Rheingold forms to its beginnings: 103 245-7, the last built locomotive of its class to be built, in front of the scenery of Stahleck Castle travels with TEE 7 "Rheingold" (Amsterdam - Basel) through Bacharach railway station on 29 August 1985. Photo: Peter Schiffer / Eisenbahnstiftung

The aim was to offer wealthy customers a level of comfort that would set new standards. With a length of 23.50 metres over buffers (luggage van: 19.68 m length), they were longer than usual for the time, their cream-purple finish together with gold-plated lettering provided for inimitable elegance.

This also continued inside with wide armchairs, fine woods and carpets as well as service at the seat. Two cars were each supplied with a kitchen. This was always done within the same car class to which the respective dining car belonged.

At the beginning of the 1930s, the saloon cars were supplemented on the outside by two raised Rheingold inscriptions in gold, although some changes to the original concept were foreseeable. In the middle of the thirties, more modern cars were finally in service and made the Rheingold look partially overhauled.



On 20 May 1951, the Rheingold Express, reintroduced as the F train, arrived at Köln Hauptbahnhof (Cologne central station) from Hoek van Holland. The train, which is mainly made up of skirted cars, is pulled by a class 03¹⁰ express steam locomotive with an old building boiler. Photo: Fischer / Eisenbahnstiftung

Nor did it prove to be a permanent and probably unprofitable solution to carry two complete dining cars with kitchens in each train. A wagon equipped in this way would normally be sufficient. The combined 1st and 2nd class coaches with a smaller kitchen apparently had not been steered in the wrong direction.

Obviously also travellers complained about smells from the kitchen and the running of the waiters through the saloon area, which the DRG especially did not want to impose on its most solvent customers. This led to plans that aimed to separate the seating cars from the dining cars, but were no longer carried out due to the war.



In 1962 the Rheingold was to be launched again as a luxury train in a contemporary form. Since the “creases” were not completed in time, E 10s equipped with Henschel test bogies from the current production were used as temporary solutions. One of them was E 10 1244, which the photographer accidentally caught on 9 May 1962 during a test run at Prien station. Photo: Ron Amberger / Eisenbahnstiftung

Only the best that the Deutsche Reichsbahn had to offer was used as the locomotive for the Rheingold. These were above all the S 3/6, considered to be the most beautiful steam locomotive series, from whose series the “high-heels” as well as the replicas of the twenties came to the special honour.

The Baden IV h, registered by the Reichsbahn as class 183, was also allowed to join the ranks. As the stock of standard locomotives grew slowly, class 01 as a showpiece locomotive for the FFD 101/102 could not be missing.

Customs and passport clearance in the moving train was almost revolutionary, and it considerably accelerated travel times. This took place between the two Basel stations and between Zevenaar and Duisburg and was one of the outstanding arguments in favour of this connection. This procedure was not to become generally accepted until much later in 1957 with the introduction of the Trans-Europ-Express.

New beginning from 1951

But the glory was over when Europe steered into the Second World War. It was to take until 1951 before another Rheingold - under a name that changed several times - came into operation. The Deutsche Bundesbahn integrated the former "Hotel auf Schienen"(hotel on rails) into its new F-Zug network, but revived it with all three car classes. This was also unusual for an F-train.

And although the pre-war rolling stock that DB had at its disposal was remanufactured, the earlier cars did not return to the train. Instead, Group 39 apron cars were used, the most modern wagons that had been produced before the war, albeit with significantly reduced comfort at the level of the other trains. .



When Ulrich Budde captured the cobalt blue and beige Rheingold set with E 10 1265 from the Hohenzollern Bridge in Cologne Central Station on 15 May 1966, the train was already running as TEE 10 "Rheingold". Photo: Ulrich Budde (Bundesbahnzeit)

In order not to promote any associations with the Reichsbahn abroad from 1937, the railway administration in western Germany renounced its abbreviation DB in sublime form. It preferred to write "DEUTSCHE BUNDESBAHN" in silver letters on the trimmings of the Rheingold in order to stand out clearly from it.

With the German economic miracle and Europe moving closer together, the demands of customers also increased. In 1960, DB remembered the former prestige bearer and wanted to revive it to its old glory.

To achieve this, he had to put everything that was on German tracks in the shade. From 1957, this included the Trans-Europ-Express in the form of the benchmark-setting VT 115. DB decided on a locomotive-hauled train with electric traction because the electrified network in the south and the island in the Rhine-Ruhr area finally grew together via the Rhine rail.

Surveys among customers showed that the majority of them wanted classic compartments instead of an open salon. DB took this and its requirements into account with the development of four new fully air-conditioned basic types. The new cars were uniformly 26.40 metres long over buffers and thus followed a new UIC standard.

A new type of observation car based on models from the United States, a compartment car and a large-capacity car as well as the first dining car developed after the war were purchased. It had two floors in the kitchen and scullery, which is why its roof was raised. It was used as a humpback dining car in the vocabulary of railway enthusiasts.

The train, composed of these carriages, started its service in 1962. In colour it was based on the TEE, but the red belly band had been replaced by one made of cobalt blue. Surely this was no coincidence and should be leaned probably purposefully against the former Rhine gold.

The new F train was also pulled by the most modern locomotives the DB had to offer. From the very beginning this was supposed to be the E 10 in a design that had been upgraded for 160 km/h and had a streamlined crease. Since it was not completed in time, colour-coordinated box locomotives ready for delivery were given the bogies for a transitional period.

The same game was repeated a year later, when the Rheingold was given a brother with the Rheinpfel, with whom course cars were exchanged from then on. From now on, Dortmund and Munich were also included in the high-quality connections. Reproductions of the proven cars and locomotives completed the stock.



The special feature of the new “Rheingold”, apart from the Buckels dining cars, was above all the ADÜmh 101 observation car, which remained unique in Germany. With the upgrading to TEE, the trains soon changed their colours to purple/beige. The car 81 - 80 004 belongs to the replicas for the “Rheinpfel” from 1963, recognizable by only four side windows in the viewing area. Here the wagon is on 1 August 1976 for a revision to guest in the Bw Cologne Bbf. Photo: Peter Schiffer / Eisenbahnstiftung

However, there was still a gap in the electrical network between the Ruhr area and the border with the Netherlands. For this reason, diesel locomotives were used in Duisburg for the time being. In this section, the luxurious train was transported by the V 200 in its first design, which was also legendary.

However, she was not allowed to take the observation car, which was unique in Europe, across the border; it was separated from the train in Duisburg because the NS had expressed reservations about its use. But even without it, the comfort of the new cars was unique and extraordinary. So it was only a question of time, especially in the context of electrically powered TEE car trains in France, when the Rheingold was raised to the highest formal level.

This was carried out by the participating railways at the timetable change in 1965. Rheingold and Rheinfeil were successively converted to the agreed colours and now ran as TEE with changing train numbers.



In May 1966, V 200 083 was responsible for transporting the "Rheingold", now known as TEE, in the sections without contact wire. As can be seen on this photo, the observation wagons always only ran from/to Duisburg main station because they were not allowed to travel to the Netherlands. The train was picked up in Oberhausen-Sterkrade, which is already connected to the contact wire. Photo: H. D. Kremer / Eisenbahnstiftung

While the Rheinfeil, a purely domestic arrow, lost this status early on, it remained with the Rheingold until the end: He should be the last German TEE, whose further history we only want to briefly shed light on.

A train past its zenith

In the seventies the Buckelspeisewagen (humpback dining cars) left the fleet and were replaced by single-storey new construction, only a few years later the observation cars disappeared from the train without replacement. Thus the Rheingold had become a quite ordinary train of the highest category TEE or IC, because its remaining cars had long been built to a standard and only slightly changed.



Since 1983 there was a wing train to Munich, which ran as TEE 16/17, and first in Mannheim, from summer 1985 in Mainz was separated from the main train. But this last resuscitation attempt with train run over touristic interesting routes off the main roads ran without the desired success. When 112 494-0 was photographed with TEE 17 in Heidelberg on 7 March 1987, its last months of operation had already begun. Photo: Helmut Röth / Eisenbahnstiftung

Of course, the Bundesbahn did not like the decay of its flagship train and the TEE, in general, and so it devised a new concept that was also tourist-oriented. The Rheingold finally experienced its fourth premiere on 29 May 1983.

In the summer months, its route led from Mannheim in the form of a wing train to Munich through landscapes off the beaten track. Also new was the Rheingold Club Car (second behind the locomotive in the picture above), which was intended to entice with special events such as folklore or regional specialities. The train could now be recognized from the outside by an orange strip between the window band and the abdominal bandage.

But the Rheingold had passed its zenith. Obviously there was no longer a permanent place in Europe for a purely first-class train. The DB had actually already recognized this, because in 1979 the IC had already been finally converted to two-class. The new concept didn't seem to work out either, because several changes in routes and destinations indicate hectic rescue attempts.

And so the final end followed. On 31 May 1987, the new Eurocity with both car classes succeeded the Trans-Europ-Express. With it came the end of the Rheingold, which since then has only survived as a nostalgic product.

The Deutsche Bahn AG and the AKE have repeatedly remembered it and offered nostalgic journeys with sets typical of Rheingold and Rheinpfel (Rhine Arrow). Other companies also sprung up and see worthwhile sources of income from the train name with its aura.



As guardian of a tradition and keeper of a train legend, however, the Freundeskreis Eisenbahn Köln e.V. (FEK; non-profit organization), founded in 1955, has endeavoured to obtain the trademark rights for the historic logo from the DRG era. Its accomplishments also include the preservation of many original cars from all epochs of this most famous German train.

From the beginning of the seventies onwards, these efforts finally led to the operational reconditioning of a five-piece set from the early years. Above all, this success has kept alive the people's memories of this special train to this day.

A special honour was bestowed on this set on 23 October 1977, which we would like to present as a representative of the railway's historical, tourist and cultural efforts: As D 25937, it left Emden on that day to become the last train of the Bundesbahn to start its journey to Rheine, steam-powered, as planned.



The last steam-powered DB passenger train was also the Rheingold cars of 1928. 043 196-5, which had survived at Salzbergen station, pulled the D 25937 special train from Emden station on 23 October 1977. Photo: Wolfgang Bügel / Eisenbahnstiftung

Photo on page 29:

This photograph should stand for the preservation of the cultural heritage and tourist efforts. On the occasion of the 50th anniversary of the Rheingold, this scene was recreated on 14 April 1978 with the museum locomotive 18 505 and historic FEK carriages in front of the backdrop of the Kölner Dom (Cologne Cathedral). Who doesn't know this well-known motif? Photo: Peter Schiffer / Eisenbahnstiftung

Before it, the likewise well preserved 043 196-5 bid farewell to her friends after 142 years of steam locomotive service in Germany. There could hardly have been a more worthy train.

Short model overview

There is no way past the Rheingold in any gauge. The only astonishing thing about Z gauge is that so far no one but Märklin has produced this model. The people of Göppingen have done it all the more intensively, and almost regularly there are theme-related implementations in the programme.

But gaps remain which could just as well have been closed by small series manufacturers. We are thinking here of the class 18³ express steam locomotive, the baggage car with a sleek roof pulpit matching the Schürzenwagen (skirted car) or the club car of the last four years. We have also been looking in vain for a Series 01 with Wagner sheet metal and DRG addresses.

Instead, the 1928 set was already found three times in Märklin's range: the first was in 1990, when the model from the early 1930s (Art. No. 8133) was put in a book cassette. Gold-coloured printed platoon name inscriptions on the pages were characteristic. But the steam locomotive of the class 18 434 with windshield was not appropriate.



The train package 8133, shown here with 18 434 in full length, was the first Rheingold conversion in gauge Z in 1990 according to the historical model. On the other hand, a class 103 with TEE train cars had already been offered since the seventies.

This mistake was repeated in 2002, when the cars appeared without the lettering and with the steam locomotive of the same company number (81 426) in Bavarian state railway colours. This train package marked the original appearance of 1928.

The 2003 edition, on the other hand, also included five cars and the well-known steam locomotive, fell into the tourist era. While the saloon, kitchen and luggage cars corresponded to the 1990 edition, the steam locomotive now wore a blue dress and colour-contrasting areas on the driver's cab and tender, including the Rheingold lettering.

Although this design is not historically correct, it corresponds to a paint job co-financed by Märklin to preserve the operational machine with the former company number 3673. The oldest Rheingold reproduction in the model dates from the year 1974.



For the 1951 Rheingold Express, Märklin produced a "Loreley" apron pack in 2003, in front of which we stretched the 01 147 (art. no. 88011; top picture). The FD "Rheingold" in the northern section from Duisburg to the Netherlands can be reproduced with the V 200⁰ (88203), and the car from the Rheinpfel pack 81439 (photo below).

In line with the class 103 (8854), Märklin also offered compartment (8724), large-capacity (8725), dining (8726) and observation wagons (8728) of this train with train running plates Munich - Bremen, which were suitable for IC traffic after the disappearance of the observation car.

The still missing humpback dining car should follow only many years later. In 2004 it finally appeared as a new shape in a three-part MHI car package (87265). The indispensable viewing car was enclosed with the three-part supplement (87285), but was not labelled exactly to the prototype with the lettering "Rheingold" below the pulpit.

Märklin declared the form variant of the Munich-based E 03 004 (88541) as the suitable locomotive, which probably only pulled the Rheinpfeil ending or beginning there. After all, from this year on an important shape gap was closed.



The Rheingold of 1962 with provisional covering by a box locomotive of the class E 10¹² (81412) we encounter on the Loreley module by Hans-Georg Kunz (picture above). The transition period between FD and TEE, on the other hand, is marked by the 81439 train pack.

Nevertheless, the Buckelspeisewagen (humpback dining car) has so far appeared only one more time, namely in the cobalt blue-beige coloured execution as a component of train packing "Rheinpfeil" (81439) from the year 2007. The special feature of this arrangement with "Bügel falte" (crease) was the mixing of red and blue at the belly bandages, the time of the conversion was marked between 1965 and 1966. Unfortunately, the locomotive had smaller printing errors in the area of the decorative lines.

Nevertheless many Zetties were thankful for this novelty, because only with this Buckelspeisewagen (humpback dining car) could the 1998 train pack "Rheingold" (81412) be completed. It was kept in cobalt blue beige and consisted of five cars as well as the provisional E 10 1243. Also here the observation car of the Rheinpfel design had the wrong name for the train.

The fact the re-ordered cars of the Rheinpfel design, with only four instead of eight side windows in the panorama area, appeared in the trains of the Rheingold, either due to circulation or due to failures, was admitted here. If the lettering had been omitted or replaced by "Deutsche Bundesbahn", Märklin would have been closer to the original.



Also the D 25937, three days before the final extinction of the boiler fire of the last steam-guided passenger train of the DB, we could simulate with the cars from the package 8133 and a renumbered class 043 (88974). The necessary computer signs of the 043 196-5 come from HOS-Modellbahntechnik.

One last locomotive, important for the history of the Rheingold, did not appear until this year. With the V 200 052 (88203), it is now possible to adjust the diesel traction section correctly. The TEE set (87269) and the revised 103 series with glass inserts in the engine room windows and LED lighting inside, did not appear in time for the 90th anniversary of the luxury train.

This also applies to the historical composition (81332), which will be identical to the first edition of the Rheingold. Their buyers will soon be convinced by the new drive with a bell-shaped armature motor, which was also used for the 103 series. This at least ensures that a round company anniversary can be celebrated here, because the models from the years 1928 and 1962 were innovative, as well.

Pages about the historical train:
<https://www.rheingold-zug.com>
Model implementations:
<https://www.maerklin.de>

Digital model railway control (part 6) Practical beginner experiences

As part of this year's focus, we have taught the electrical basics and basic knowledge for digital operation. In each article, a great deal of knowledge was acquired for digital introduction and understanding of this operating mode. Inspired by reader questions and feedback, editor Dirk Kuhlmann also went to work himself to gain his own experience.

By Dirk Kuhlmann. With great attention and thirst for knowledge, even the editorial staff has followed our digital annual focus in recent months. In this context, I myself have spoken to many Z-gauge railroaders and listened to their little worries and problems regarding digitalization.

My first personal experiments, in consultation with some electronics engineers, will be shown for the first time in this edition, which will hopefully help you a little with the implementation of your system. So I hope to be able to pass on one or the other tip.

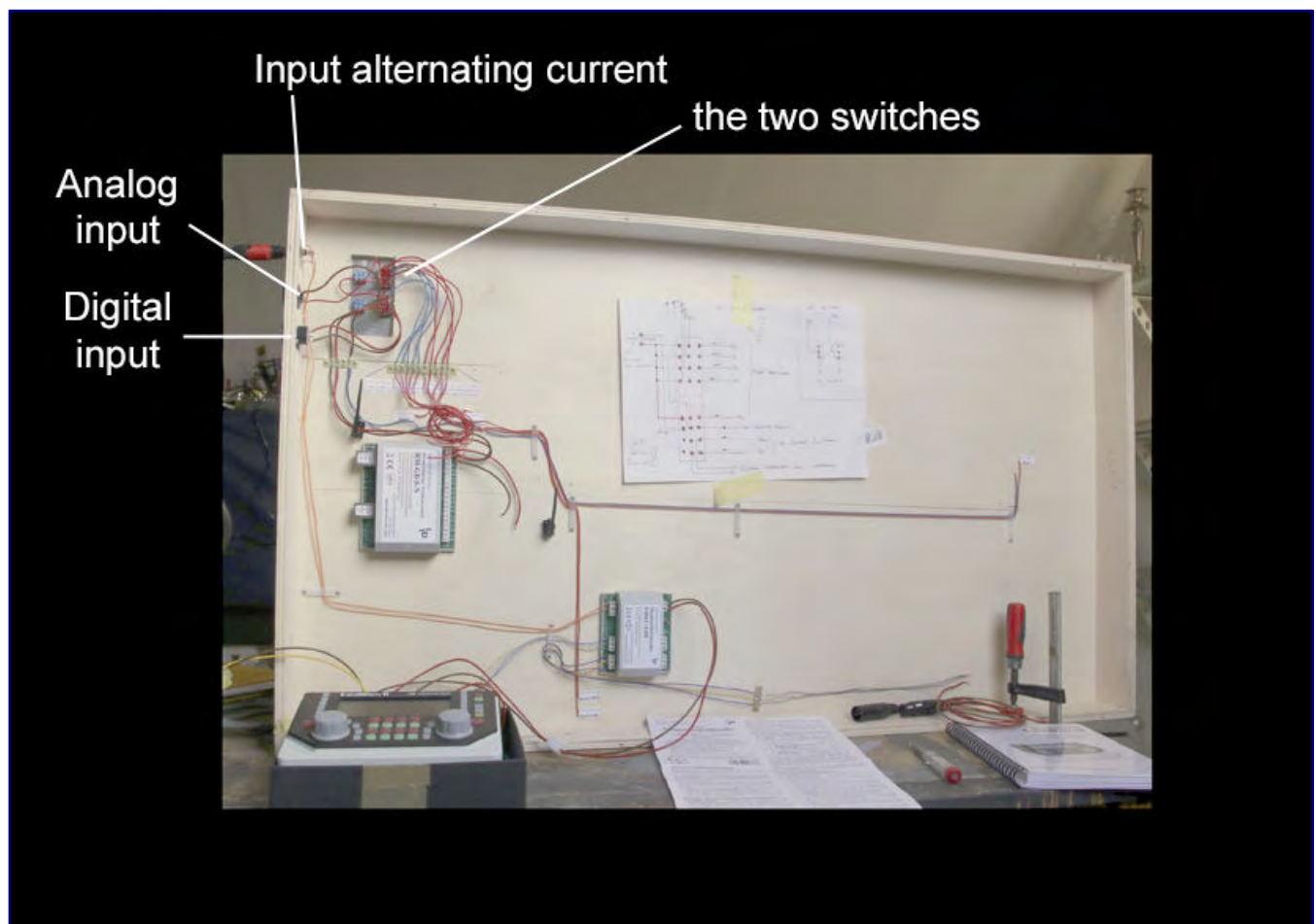

This is what the test system looks like from below, here are still detectors and decoders correctly connected according to the manufacturer's description.

Of course, some of our readers certainly have even better solutions, but there is always the lowest denominator to be used. By far the largest number of all model railroaders would like to switch on the transformer or the digital control panel after laying the cables and simply ride off.

Often the model railroader has a considerable selection of analogue models in the showcases or in the suitcase, but there are only a few digital models for cost reasons.

However, simultaneous driving on one and the same layout is only possible if an inner or outer circuit could be easily switched. On a single-track line, there is only an " either... or ".

Of course (many) digital locomotives, as long as the respective decoder allows it, can also run analog, but the beloved functions would not be usable in this mode.

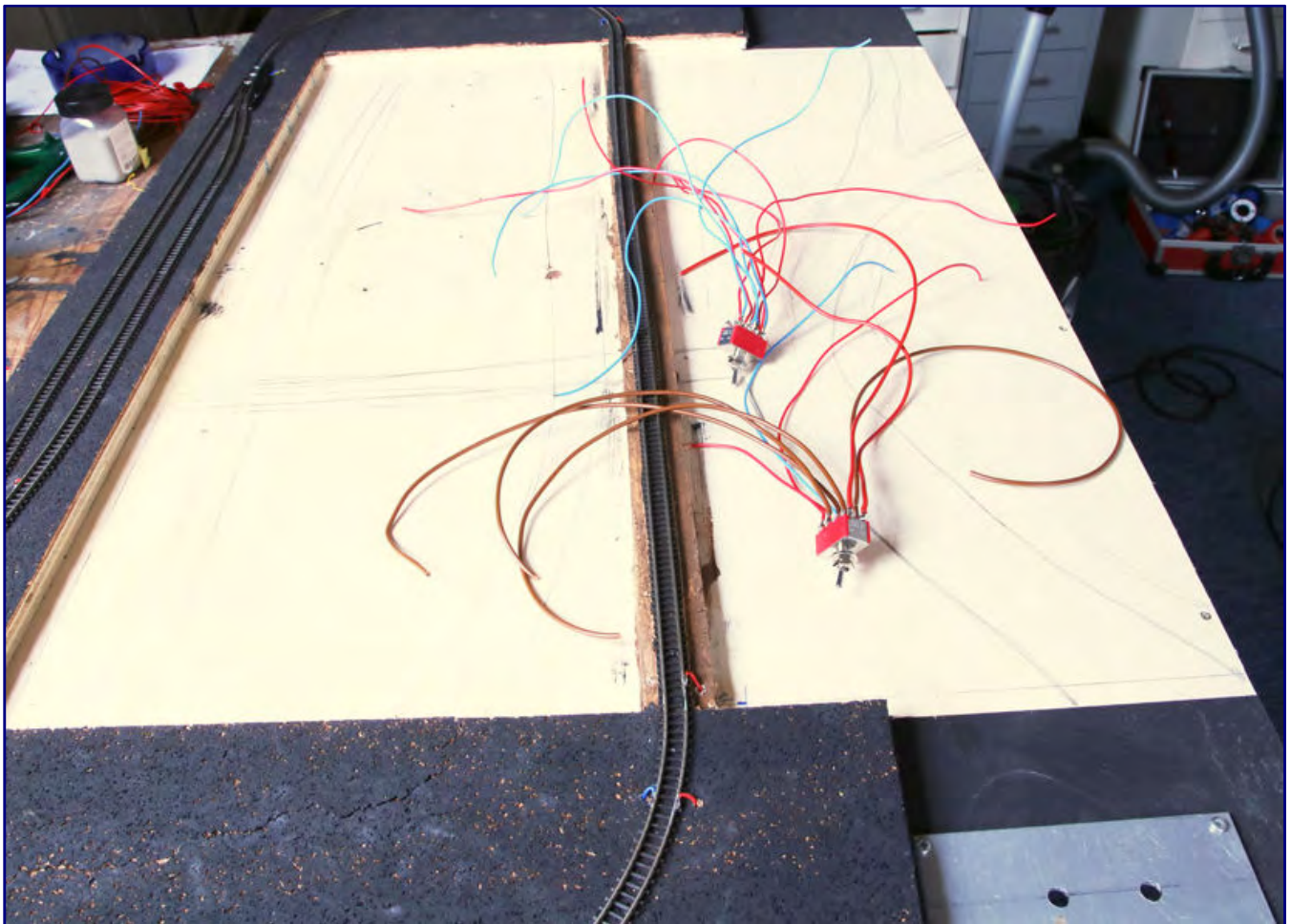

The two switches were carefully soldered to the corresponding coloured cables at the craft table and are waiting to be installed in the test facility.

As long as there is only one circuit without further digital connection (sensors, brake circuits, etc.), either a transformer or the digital control unit can be connected. Beyond that it becomes supposedly more complicated.

A occupancy detector and a turnout decoder are installed on my test layout. Out of concern not to damage the digital components during analog operation, a simple (analog) switch technology is installed. Two toggle switches (4 x on/on latching; Conrad order no. 705139-62) effectively fulfil their purpose here.

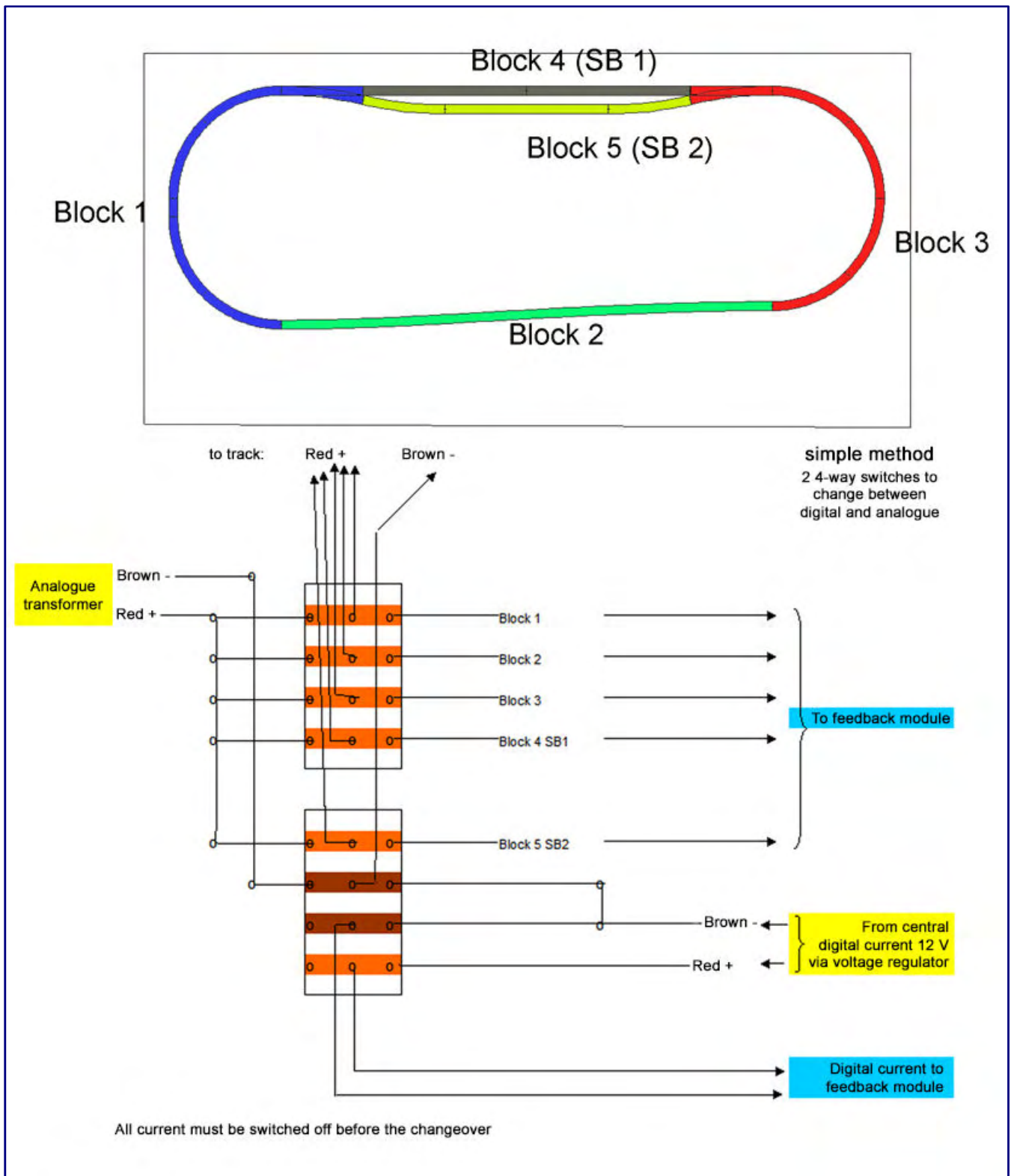

The schematic sketch for switching the test system is simple and effective.

With the analogue setting, the occupancy detector is completely bypassed and the digital current is also interrupted. Have a look at my small circuit diagram, which is deliberately kept simple.

To avoid connection errors, the transformer and the digital control unit should each have a separate input. This prevents any mix-ups. When I swap my system, I always switch off the entire power supply beforehand.

Of course, a comprehensive switching technology with considerably higher safety would also be possible here, but at the beginning we spoke of the lowest common denominator: Where would such a circuit still make sense?

Think, for example, of a demonstration with an audience, possibly at an exhibition. All of a sudden, that's

What will happen with the focus for the year?
This article concludes our annual focus topic for 2018. However, there are concrete plans for two follow-up articles on the topic of "decentrally installed intelligence", which will deal with the controls of Gahler + Ringstmeier and Alan. A look back into the history of digital Z track is also planned. Further articles on digital topics will be published in the always relevant editions.

how it always is, the train sets stand still on the layout. The operator and the spectators watch each other with perplexed glances, the first "expert" knows of course why. Now the confusion is increasing and everyone would wish to avoid such "demonstration effects". And now you can switch!

While your exhibition helper can continue operating with the analog models, it is possible to check the digital technology in parallel. Sometimes only a small cable end has come loose somewhere.

So this simple circuit at least brings some calmness in the hectic of a presentation and the search for the error without ending in a sweat outbreak is possible - everything works at the visible part of the exhibition! With home layouts also the run-out for our analog "sweethearts" is further and at any time possible.

But you miss the circuit for the turnouts? We will be taking up this topic in one of the next issues of **Trainini®**.

In the current setup I can use my test circuit to drive analog sets, but I switch the turnouts digitally. I don't think that's a bad thing either, especially since some of the control centers have pre-installed "passageway" modes. With my two turnouts it's more of a joke, but with a bigger turnout field it's a really nice thing. And it works!

Source of supply for electronics in Germany:
<https://www.conrad.de>

MODELLBAHN

Ausstellung in 3 Hallen

19. und 20. Januar



Öffnungszeiten: Sa. 10-18 Uhr und So 10-16 Uhr

Elisabeth-Selbert-Gemeinschaftsschule, 23611 Bad Schwartau, Schulstraße 8

Bitte benutzen Sie die großen öffentlichen Parkplätze, und folgen Sie den Wegweisern!

- **Nördlichste Spur Z-Convention Deutschlands**
- **Spur N – Mehrere Modulanlagen**
- **H0 - Verschiedene Modulanlagen**
- **Schmalspurbahn H0e**
- **Spur 0 – Große Modulanlage**
- **Straßenbahnanlage**
- **Große Modellbahnbörse**
- **Cafeteria**

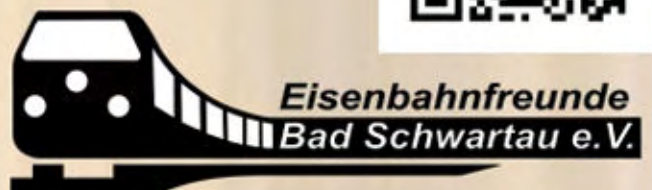

*Eisenbahnfreunde
Bad Schwartau e.V.*

Eintritt: Erwachsene 4,-€, Kinder 2,-€ und Familien 10,-€, Kinder bis einschl. 6 Jahre frei

Die Erlöse dienen der Vereinsarbeit und dem Erhalt des Stellwerkes "Sn" in Bad Schwartau

www.efs-badschwartau.de

Motiv/Foto: Martin Engelbrecht

Note for English readers: The literature section that follows is not translated into English because the original texts of the books involved are in the German language. The original German is left here for information purposes only.

Dieseltraktion bei der DB

Fotocollage vom Altmeister

Kaum eine Eisenbahnfotograf wird kommerziell so stark strapaziert wie Altmeister Carl Bellingrodt. Umso verwunderlicher ist es da, wenn wir immer wieder mal schöne und ansprechende Bücher finden, die eben nicht das Gefühl hinterlassen, doch alles schon irgendwoher zu kennen. Das heute besprochene Buch aus dem EK-Verlag ist ein solcher Titel mit Mehrwert.

Norman Kampmann u.a.
Dieselloks und Dieseltriebwagen
Aus dem berühmten Lokomotiv-Bildarchiv von Carl Bellingrodt

EK-Verlag GmbH
Freiburg 2018

Gebundenes Buch
Format 26,0 x 21,5 cm
144 Seiten mit 160 S/W-Fotografien

ISBN 978-3-8446-6211-5
Best.-Nr. 6211
Preis 29,80 EUR (Deutschland)

Erhältlich direkt ab Verlag
oder im Fach- und Buchhandel

Carl Bellingrodt – der Name dieses längst verstorbenen Altmeisters der Eisenbahnfotografie scheint auch heute noch über viel Zugkraft zu verfügen. Würden nicht sichere Verkaufserfolge locken, wäre die heutige Vielfalt an Bildbänden und Veröffentlichungen aus seinem Bildarchiv wohl kaum zu erklären.

Auch der vorliegende Band, der sich mit der Dieseltraktion der Deutschen Bundesbahn beschäftigt, ist nur ein Titel aus einer größeren Reihe: Fünf lieferbare Bücher sind es, die beim EK-Verlag auch nur einen Teil der Veröffentlichungen darstellen.

Doch für den Interessenten besteht hier kein Grund zur Sorge! Zwei größere Archivbestände aus Bellingrodts Erbe, einer davon in Händen dieses Verlags, sind bekannt, dazu kommen weitere Aufnahmen im Streubesitz. So verwundert die thematische Dichte beim Eisenbahn-Kurier nicht.

Überraschend ist und bleibt eher, wie bunt die Fülle an Aufnahmen ist, die zur Veröffentlichung gelangen. Dabei spielt es nur eine untergeordnete Rolle, ob ein Bild als Wiederholung in einem Werk auftaucht oder tatsächlich noch als (weitgehend) unbekannt gelten darf.

Zu Recht gilt Carl Bellingrodt als Könnler und hervorragender Dokumentar; von seinen Arbeiten werden Eisenbahnfreunde sicher noch viele Jahre profitieren und von seinen Perspektiven und Vorlieben lernen können. Denken wir nur an die schon sprichwörtlich gewordene „Bellingrodt-Stellung“ einer Dampflok: Der Altmeister legte Wert darauf, dass der Kreuzkopf in der Mitte der Gleitbahn stand und das Triebwerk so möglichst harmonisch auf den Betrachter wirkte.



Dafür ließ er sich zu fotografierende Maschinen zunächst in die gewünschte Position fahren, bevor er seine bevorzugte Perspektive festlegte und den Auslöser betätigte. Das mag auf Unbedarfte wie die Allüren eines Künstlers wirken, für Liebhaber seiner bildlichen Zeugnisse ist es die Handschrift einer Person, die ihr Handwerk verstand.

Und so lebt auch die aktuelle Zusammenstellung abseits der Dampflok von diesen Fähigkeiten. Glücklicherweise hat der schon legendäre Eisenbahnfotograf des 20. Jahrhunderts neben ihr auch die elektrische Traktion und Diesel-Triebfahrzeuge auf Bildern festgehalten.

Aus diesen Aufnahmen entstand in fachkundiger Auswahl durch die EK-Redakteure ein Bildband, der zugleich der erste über die Diesellokomotiven und Diesel-Triebwagen der deutschen Eisenbahnen in der Bellingrodt-Edition ist.

Fast versteht es sich von selbst, dass alle 160 Schwarz-Weiß-Bilder nicht nur fachkundig aufgenommen, sondern auch hervorragend reproduziert wurden. Das macht dieses Buch zu einer Fundgrube für Liebhaber historischer Aufnahmen und macht es zugleich zu einem wertvollen Dokument für vorbildnahe Umsetzungen.

Allerdings haben wir bis hierher noch kein Wort über die inhaltliche Auswahl getroffen. Auch diese ist durch und durch als gelungen zu bezeichnen. Was der Titel nicht verrät, ist seine Einschränkung auf das Gebiet der Bundesbahn. Kenner werden aber auch nichts anderes erwartet haben.

So bleibt es hinzuzufügen, dass im Buch durchaus Ergänzungen aus Beständen zeitgenössischer und nicht minder bekannter Fotografen auftauchen. Genannt sei mit Hermann Maey nur der Bekannteste unter ihnen.

Diese Konzeption führt dazu, dass nach Baureihen numerisch geordnet, alle wichtigen Konstruktionen der deutschen Dieseltraktion im Buch auftauchen, bedeutende Einzelgänger eingeschlossen. Die Auswahl macht auch vor Schmalspur und den Reichsbahn-Bauarten für frühe Schienenbusse nicht Halt.

Sogar eine US-Vorführlök auf deutschen Schienen fand, wie auch die berühmte NOHAB, Eingang in dieses Werk. Den meisten Fahrzeugen sind sowohl Portrait- als auch Streckenaufnahmen gewidmet. Darin sehen wir eine weitere Bereicherung, die das Buch nahezu einmalig macht.

Einen zeitlichen Schnitt muss der Käufer aber, bedingt durch das Eingrenzen des Wirkens, akzeptieren: So finden wir die Baureihe V 160 als Vorserie und endgültige Ausführung wieder, nicht aber die späteren Vertreterinnen dieser Lokfamilie, allen voran die Gasturbinenlok Baureihe 210 oder die erfolgreichste Variante in Form der Baureihe 218.

All das lässt sich aber auch verschmerzen, denn dies gehört ja auch längst in die Farbbildära. Der rezensierte Bildband hingegen gehört in eine Zeit, in der die Magistralen noch nicht elektrifiziert waren und Diesellokomotiven und Schnelltriebwagen den hochwertigen Dienst bestritten.

Weniger populäre Maschinen waren bestimmt, um im Rangierdienst oder höchst defizitären Nebenbahnbetrieb die Dampflok abzulösen. Hier erleben wir eine Zeitreise, die das abwechslungsreiche Schaffen Carl Bellingrodts erlebbar macht. Gut ist es da vor allem, dass er sich den „Totengräbern der Dampflok“ im Gegensatz zu vielen Zeitgenossen nicht verschlossen hat. Seine Zeugnisse sind unwiederbringliche Dokumente einer längst vergangenen Ära.

••••• Publishing pages with reference possibility: •••••
••••• <https://www.eisenbahn-kurier.de> •••••
••••• <https://www.ekshop.de> •••••

Deutsche Technikgeschichte Das Auto-Standardwerk 2.0

Eine verdammt dicke Schwarte liegt vor uns, noch dazu zum modellbahnerischen Randthema Automobil. Wer braucht dieses Buch und was es nützt es uns? Fragen über Fragen, noch dazu angesichts eines neuen Titels von einem Autor, der bereits vor 21 Jahren verstorben ist. Wir klären auf!

Werner Oswald
Deutsche Autos 1945-1975

Motorbuch Verlag
Stuttgart 2018

Gebundenes Buch
Format 23,0 x 26,5 cm
520 Seiten mit ca. 1.000 teils farbigen Abbildungen

ISBN 978-3-613-04102-8
Titel-Nr. 04102
Preis 49,90 EUR (Deutschland)

Erhältlich direkt ab Verlag
oder im Fach- und Buchhandel

Werner Oswald gilt als fundierter Kenner deutsche Automobilgeschichte und war einst als Journalist unter anderem für die Zeitschrift „Auto, Motor und Sport“ tätig. Er prägte zusammen mit seinem Chefredakteur den Begriff vom „Erlkönig“, dem noch getarnten Prototyp für eine neue Fahrzeugserie.



Was auf den ersten Blick aber verwundern mag, ist das Erscheinen eines neuen Titels unter seinem Namen. Werner Oswald ist nämlich bereits 1997 verstorben und beendete sein schriftstellerisches Wirken Ende der siebziger Jahre.

Wollte sich der Verlag da womöglich nur eines berühmten Namens bedienen, um seine Auflage zu steigern? Nein, da können wir die Leser dieser Zeilen beruhigen. So neu ist das Buch nämlich gar nicht, eine reine Wiederauflage des älteren Werkes ist es aber eben auch nicht.

Vor uns liegt die zeitgemäße Überarbeitung eines echten Klassikers, eines Standardwerks zur Nachkriegsgeschichte deutscher Autos bis Mitte der siebziger Jahre. Die Inhalte schließen etwa mit derselben Epoche, die auch den Fokus der meisten Modellbahner – nicht nur der Spur Z – eingrenzt. Und, so viel sei verraten, diese 30 Jahre haben viele und große Klassiker hervorgebracht, die noch heute zu Recht bewundert werden.

Lesenswert wird die komprimierte Geschichte des deutschen Automobilbaus in der Nachkriegszeit vor allem durch die treffende und fachkundige Weise, mit der Werner Oswald sie zu beschreiben wusste. Diesen wohl unnachahmlichen Stil haben die Verantwortlichen des vorliegenden Titels, dafür sei ihnen gedankt, belassen und ein Standardwerk nur mit zeitgemäßen Farbaufnahmen weiter bereichert.

Modern und ansprechend präsentiert sich das oft nachgefragte und längst vergriffene Hauptwerk des legendären Autochronisten nun endlich in einer überarbeiteten Neuauflage. Zu erwähnen bleibt da noch,

dass es selbst schon eine Ergänzung war, die noch aus der Feder des Autoren stammte. Ursprünglich schloss die Chronik im Jahre 1966.

Die neun weiteren Jahre, die er selbst hinzufügte, hatte er schon unter geänderten Voraussetzungen aufgearbeitet. Enorm erweiterte Modellangebote und immer endloser erscheinende Preislisten für Sonder- und Zusatzausstattungen zwangen zu einer veränderten Darstellungsform. Das kennen wir auch heute in stärkerer Form, nur Ausstattungen sind inzwischen in mehr oder minder sinnvollen Paketen gebündelt worden.

Und so listet das vorliegende Werk mit wahrhaft mächtigem Umfang nicht nur penibel auf, was die Werkshallen der deutschen Automobilhersteller verließ. Es schafft gleichzeitig Klarheit bis zum letzten Nischenmodell und längst vergessenen Herstellern. Die eingefügten Tabellen erläutern und ergänzen in strukturierter Form wichtige Informationen technischer Art oder auch zu den Preisen von Basismodellen.

Wer dies auf die zeitgenössische Kaufkraft und Einkommensentwicklung umrechnen möchte, der wird nicht nur an den Automodellen selbst nachvollziehen können, wie sich das einstige Luxusgut zum Massenverkehrsmittel entwickelte.

Alle Aufnahmen, gleich ob schwarz-weiß oder farbig wiedergegeben, sind hervorragend geeignet, um die Textausführungen zu dokumentieren und so überhaupt nachvollziehen zu können. Das gilt nicht nur für solche meist unerreichbaren Traumautos wie den Porsche 356 oder den Mercedes-Benz 300 SL mit Flügeltüren.

Auch einst ganz gewöhnliche und dennoch besondere Fahrzeuge wie Opel Kapitän, VW Käfer, das Goggo-Mobil, den „Maurerporsche“ Ford Capri oder den Manta als Konkurrenzmodell von Opel wird hier ausreichend Platz eingeräumt.

Auch beim „Badewannen-Taunus“, dem VW Golf oder Passat oder dem schon legendären Opel GT endet die Themenfülle nicht. Auch andere bekannte Marken wie etwa BMW finden sich vom „Barockengel“ über die Isetta bis hin zum zeitgemäßen Fahrzeug der siebziger Jahre hier wieder. Dazu gehören auch „Heckflossen“ von Mercedes-Benz, die vorherige Pontonkarosserie und das Erfolgsmodell „Strich-Acht“.

Und zu jedem der bekannten oder längst vergessenen Hersteller hat Werner Oswald geschichtliche Abrisse zusammengestellt, anhand derer sich Entwicklungen, Erfolge und auch wirtschaftliche Probleme nachvollziehen lassen. Beispielhaft sei hier das Festhalten am luftgekühlten Heckmotor bei Volkswagen genannt, das glücklicherweise mit den bereits genannten Modellen Golf und Passat doch noch aus eigener Kraft überwunden werden konnte.

Aber nicht mal da schließt die enorme Themenfülle. Wer erinnert sich heute noch an Heinkel oder Zündapp als Automobilproduzenten? Oder ist ihnen das Aufsehen erregende Amphicar von 1961 im Gedächtnis geblieben?

Mag das Auto nur eine Randgeschichte für den Eisenbahnfreund sein, der Hang zur Technik stellt dennoch eine unlösbare Verbindung her. Und die hier besprochene Automobilchronik hilft auch bei Umsetzungen und Zusammenstellungen auf der Anlage.

Wer jetzt Feuer gefangen hat, darf sich zudem auf zwei weitere Titel aus dem Nachlass des ursprünglichen Verfassers freuen. Angekündigt sind bereits die Chroniken für PKW von 1920 bis 1945 sowie eine für deutsche Lastkraftwagen. Sie dürften wohl ebenso als Geschenketipp taugen, so wie dieses Buch!

Publishing pages with reference possibility:
<https://www.motorbuch.de>

International Model Railway Exhibition A biennial highlight

In autumn 2018, the Internationale Modellbahn Ausstellung was held for the 35th time. For four days, manufacturers from the model railway and accessories sector, publishers, tool suppliers and, of course, participating associations came together at Kölnmesse. We were there for you and report in detail what was new about Z gauge.

Four days, exactly from 15 to 18 November 2018, were planned for the 35th edition of the International Model Railway Exhibition in Cologne. Nearly 200 exhibitors from 12 nations represented the current market situation and presented their products.

On the exhibitor side, the organiser registered participants from Germany, the Netherlands and Austria, Poland, France, the Czech Republic, Italy, Spain, Denmark, Belgium, Finland and even the United States.

The official number of over 50,000 visitors was probably no less international, as the distance to the Netherlands and Belgium is manageable and there are also good train connections to the cathedral city from France and even Great Britain. All in all, the fair lived up to its name and, from the point of view of the visitors we spoke to, was significantly better than two years ago.



Emma and the Lummerland complex were once again an attraction in Köln, especially for the children.

Maybe this will first have to get around again, because the number of visitors is still a little too relative.

Of course, this is not to be found in the official judgement. With a single ticket every guest gets access to three events at the same time: In addition to IMA, these are the real steam meeting and the heavily visited Lego fan world, which attracts adult Lego enthusiasts, as well as many children.

How many of the counted persons actually found their way to the model railway hall 4.1 is therefore difficult to estimate. But Köln was definitely worth a visit this year!

Before we focus on our small track gauge, we would like to point out a jubilant exhibitor: The Busch company celebrated its 60th anniversary and, as usual, could also be found on site this year. Also present and looking back on 25 years was HLS Berg.

Better known by its company name is its flagship product Trainsafe, a display case system made of acrylic glass tubes, which are also available for Z gauge.

Märklin, on the other hand, provided for an influx of visitors by again announcing the club models for the next year on site-more about that, too.

An important topic and concern of the manufacturers and clubs remains the work for the next generation. If we combine the Köln exhibition with very mixed experiences, we can attest this year's edition was very well received by the youngest audience.



With this Advent calendar Märklin sweetened this year's waiting time for its club members.

And who could know better than representatives of this target group themselves?

We are lucky to be able to send our own children into the turmoil with a journalistic assignment. Since they are hardly recognised and perceived as representatives of the press despite being labelled as such, they capture many impressions unadulterated and then report on both inspiring and disappointing experiences.



For the photo we have placed the sample of Insider 2019 (Art.-No. 80329) on the rock stage diorama.

We are glad that a lot has happened in this area over the last few years. The manufacturers such as Roco/Fleischmann or Piko are trying to attract their customers of tomorrow with playgrounds and offers, while Märklin is going one step further with accessory suppliers such as Auhagen, Busch, Faller, Kibri/-Vollmer and Noch as well as "Gleis 1".

In addition to large play areas, there are also craft tables for the youngest, where small dioramas or building models are created. Unfortunately, this offer has meanwhile been provided with a nominal fee, which

not only we regret, but also represents an obstacle for those children who are allowed to move alone and freely at the fair.

The targeted consultation with the manufacturers showed that the previously free offers were increasingly used by visitors. It was thus not always built at the table, in order to obtain experience, knowledge, and

greater interest in the hobby, but simply purposefully a free kit sample was offered, in order to enable responsible individuals to want to build this at home.

Here, we can understand the decision unfortunately, and regret this not so rare visitor behaviour, with which all attempts of the model railway industry are sabotaged. Therefore we leave here an urgent appeal to let the children be children, to give them time for a little joy and experience and to put their own greed behind!

For many years, the representatives of the BDEF, who traditionally offer the “Junior College Europe” in Köln, have been actively involved in looking after young talent. Here, the children like to take a break and create their own small works under expert supervision, which is only possible thanks to generous manufacturer support and voluntary help. We would like to take this opportunity to express our thanks and we do not take this for granted.



Apparently the railway magazine was surprised by the great response of its diorama building competition. How else can the presentation be explained, especially in the top row? For gauge Z alone, ten contributions were submitted, of which (at least) six can be seen on this photograph. But how should they unfold their effect in this crowd, especially when looking only at the narrow instead of the main presentation side?

A special highlight for children in 2018 was the “Lummerland” layout at the Märklin stand. Many still had good memories of the new film version and so the little ones crowded around the island with two mountains, on which locomotive “Emma” tirelessly made its rounds. We had already heard from Märklin in September that the demand had exceeded the first production run and would have to be re-produced.

This is good news, and makes us confident for the future of our hobby, even if it will certainly not be as important as it was in the sixties or seventies. But that today's children would no longer be interested in model railways is something we would like to point out as a fable.

But the eyes of the adults were also on this fair, and that was true regardless of their own visit to the site. Märklin surprised the club members with the announcements of the V 320 diesel locomotive for H0 gauge and a class 03¹⁰ express steam locomotive (art. no. 88850) for Z gauge.



The own diorama (E39) with a crossing light railway line of gauge Zf was originally not intended for the competition and dealt with the consequences of an extremely dry high summer under the title "Fire Watch". The challenge "Be a fox and find him" was intended as a hidden object game. Where the tiny model of C-M-K is hiding, will be answered in 2019.

Unfortunately, there was no hand sample to see for the scale 1:220 yet, but the CAD volume representations and product descriptions let the heart beat faster: The finely detailed new construction receives driver's cab side windows, brake imitations, inductive magnet and air tank at the trailing frame, rail scraper and free standing head lamps.

The complete control, drive via bell-shaped armature motor and lighting with warm white LED has meanwhile become standard. What is new, however, is that the direction-dependent lighting also includes the tender, which has pivoting flaps on the coal box and spoked wheels.

In the bogie of the locomotive with high performance boiler and high sandboxes, disc wheels roll on the circulation, suitable for the operating condition of the 03 1001 from the year 1963. Their model was the Bw Hagen-Eckesey and provided the express train service among other things on the Ruhrtalbahn in the direction of Kassel. With this model, Märklin landed a surprise and launched a vehicle that already stands out from the express locomotives of the 01 and 03 series.

With a covered G1 freight car from the former class district of Dresden in grey paintwork and a large Miele lettering (80329), the manufacturer is also fulfilling the wishes of many customers for the 2019 Annual Car.

In the club's anniversary year Märklin welcomed its members with a glass of orange juice or prosecco. As a small present for the upcoming time, they gave them an Advent calendar with 24 chocolate bars and a photograph of this year's H0 gauge christmas locomotive 01 108 to take home.



The youngest participant, at least on a scale of 1:220, was nine-year-old Julia Adass (J19) with clearing work next to the track. There's a lot going on underground, also.

At EK-Verlag many visitors stocked up again with bargains from the book program, while at VGB for the first time the new freight car line 1.1 by Stefan Carstens was on display. This title had just made it from the print shop to the sales table, where it was eagerly awaited. The former OnTraXS! regular guest Marcel Ackle signed his new book on site and had also brought one of his dioramas with him.

The events at Geramond's booth were dominated by this year's diorama competition "Along the Rail" of the railway magazine. We counted at least 57 entries, for which we even had to add another presentation board. Nevertheless, there was not enough space to present all dioramas measuring 30 x 15 cm in a worthy manner.

This was especially true for the eleven contributions from Z gauge with its tiny details, two from young people and nine from the adults. Thus, the view of many subtleties, which are what make each piece so special, was unfortunately all too often denied.



Marvin Schneider (J15), who presented the Kallental mill, can already fall back on a wealth of model making experience. He also took part in the exhibition in Altenbeken this year with another exhibit.

It is therefore very important to us to list all eleven participants here with their competition number, name and short description of their entries and to honour each of them with a picture regardless of their position - further reports are therefore not excluded:

J15	Marvin Schneider	Kallental Mill
J19	Julia Adass	Logging works
E04	Markus Krell	The storm „Kolle“ at the Ilztal line
E12	Olaf Pflüger	incline section
E15	Ralf Junius	Gravel plant „RSZ-Kies“
E16	Dietmar Allekotte	Coastal country
E24	Detlef Wolf	Block station 220
E38	Keven Horat	Underway at Gotthard
E39	Holger Späing	Fire watch
E56	Rolf-Dieter Woerz	Railway crossing with barriers

As the organiser of the competition, the railway magazine presents the three first place finishers in EM 2/2019 independent of the track gauge, places 4 to 10 finally follow in EM 4/2019.

In addition to other large suppliers such as Heki, Preiser or Viessmann, as well as Modellbahn-Union as a large dealer, we were also pleased to see many smaller suppliers offering solutions or products for Z gauge.

Text continues on page 53



Picture above:
Pastor Markus Krell (E04) had dealt with the 120 trees that had been bent and thrown onto the track by the storm "Kolle" on 18 August 2017 and showed the honorary clean-up work on the Iltal line Freyung - Passau.

Picture below:
Ralf Junius (E15) wanted to put into practice what had been learned from our 2017 annual focus topic and designed a disused, but not yet dilapidated, gravel plant. The forgotten self-unloading wagon therefore stands with an axle next to the track



On the incline section of Olaf Pflüger (E12) the route climbs high, with the large pine in the foreground dominating. The flat coastal country of Dietmar Allekotte (E16), where the railway line is directly beside the beach, appears quite different.



Rolf-Dieter Woerz (E56) had submitted the limited level crossing (picture above) which the D 823 had just passed, the last car of which can still be seen on the right. The illuminated barrier keeper's house, the truck's headlights, the lights at the block signal and the flashing emergency signal of the rescue vehicle remained in Cologne without function and thus unfortunately also without effect. With "Underway at Gotthard" (picture below), Keven Horat (E38) had used motifs from his Swiss homeland, which were impressive due to their height gradations.



Many small scenes worth seeing were built around the block station 220, with which Detlef Wolf (E24) took part in the competition. A special eye-catcher on this exhibit was certainly the flock of sheep, which temporarily paralyzes traffic on the country road.

Among others Artitec, Artmaster/Das Kantoor, Jeweha Modelbouw, Kuswa, Lütke Modellbahn, MKB-Modellbau und Modellplan as well as Tams Elektronik oder Werkzeuge Peter Post are to be mentioned here. Also regularly present are Aspenmodel and Bahls model trains. Michael Bahls impressed us with his Prussian train and deliveries of his upgraded Prussian T 16¹.

Brima was also a professional plant construction company that presented its full range of services. At MO-Miniatur, a good-humoured Christian Brunner rejoiced that something new could soon be expected for the Z gauge, as well.



At Microrama's booth, Gwendal Theis demonstrated how his technique creates the extraordinary trees, which we presented in an article in the last issue.

It was a special pleasure for us to watch Gwendal Theis from Microrama at his performances.

Helpfully, as usual, he supported us with photographs and explained to his viewers how his products create small greening wonders. We were also able to give one or the other tip, which quickly gets lost due to language barriers.

Finally we got to the stand of the Z-Friends International. Not only a warm coffee with a nice chat on technical topics awaited us, but also a wealth of very different exhibits and works.

The dwarf train already mentioned in the last issue as well as the Rokuhan bed track and a Märklin train were waiting for the children at the stand. They were happy to accept the offers, so many track sections were laid and immediately played upon. Meanwhile Axel Hempelmann explained the Z-Car system to the parents, which is still a great attraction among the visitors.



Torsten Schubert's soldering demonstrations are a great and welcome help for many model railroaders, who have previously been at war with soldering irons.

Torsten Schubert showed his lighting effect dioramas, the small exhibit "Am Mauspfad" by Dirk Kuhlmann as well as the rock stage with the Dortmund Group "Streetkings", where we could also take a picture of Märklin's 2019 Insider Year Car.

Every hour Torsten Schubert gave soldering demonstrations with explanations of the correct procedures. This was the prelude to many further discussions.

Gotthard Schmidt ventured into the recent past by demonstrating a mini club facility he had purchased from an estate. Designed with love in the style of model building from the nineties, the cardboard buildings, which we could not assign to any manufacturer, were particularly captivating.

Jürgen Wagner and his wife had also travelled back to Köln, where they presented the Almstedt-Segeste museum railway station, as they had already done in Altenbeken. The inspection of the system for the individual segments for safe electrical and mechanical connections was also very informative. From our point of view, this can also be an excellent solution for the popular Stammtisch boards.

The brisk operation on the US suitcase layout of Maria and Herbert Strauss was also a pleasure. This extensively re-designed showpiece could also be seen in Altenbeken, but was not yet in this form displayed in Köln.

And so it provided some variety among the otherwise German influenced layout scenes.

Stadtbahnhof (city train station) artist Ulrich Günther had moved to a different theme and came up with something new for Köln. There was already enough travel around him and so he presented large show-



We cannot assign the paper buildings on the plant shown by Gotthard Schmidt to any manufacturer.

cases of passenger and freight trains from different eras. Thus he found a good possibility to show his creative modifications and aging of models in a large selection.

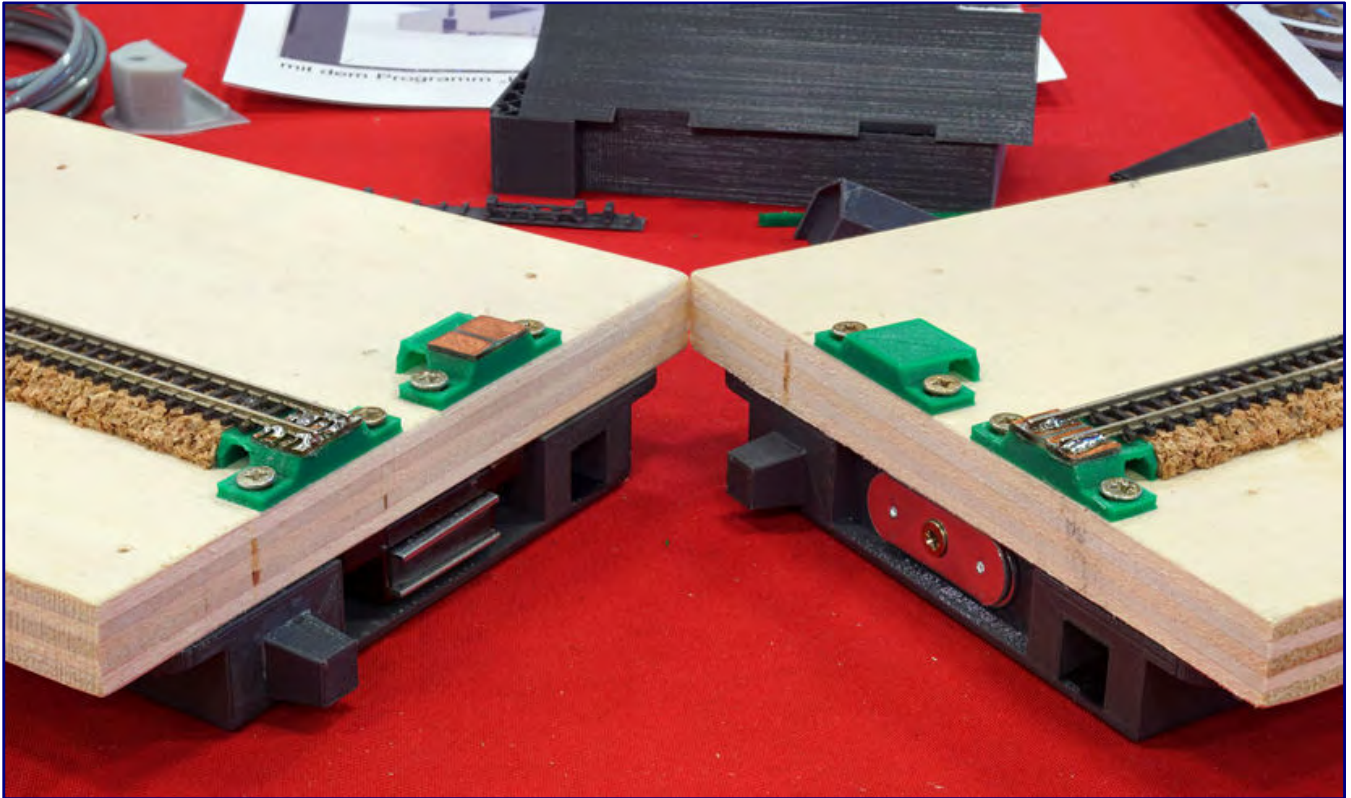

The magnetic locking system from the 3D printer and the rail crossing technology developed in-house are also used at the Almstedt-Segeste museum railway station by Jürgen Wagner. In our opinion, they may also be a stimulus and inspiration for the Stammtisch boards.

Birgit and Volker Brock (Trafofuchs) had arrived with their well-known four-season-layout, but had also implemented some highlights that the visitors might not yet have been familiar with. The trees were largely replaced here.



A part of the showcase presentation of trains by Ulrich Günther.

The new deciduous trees, which frame the lovely backdrops, showed a very realistic branch work and the finest leaf structures, applied with foliage. So this layout invited new photos and also allowed for the discovery of many scenes from famous works of art, which were three-dimensional replicated here.

No less impressive were the show-pieces in the showcases. In addition to some rolling stock, Sylvester Schmidt, ZFI's organizer and trade fair representative, also provided three special eye-catchers here.



Trafofuchs' four-season layout impressed us with its newly designed trees, which looked very realistic both in terms of their trunks and the foliage used.

Peter Friede's small rack-and-pinion diorama is certainly a piece of practice with which he has tested techniques for his latest system. As observers we enjoy the beautiful landscaping, the convincingly reconstructed rack in the track and on top of that the self-made small tender steam locomotive.



Peter Friede's rack-and-pinion diorama spreads a thunderstorm atmosphere in the area in which the self-built steam locomotive moves up the rack or back in the opposite direction.

Visitors to the fair do not get to see an “angel transport” every day either. Gottfried Endres gave the appropriate title to his marble work because of the sculptures to be loaded on heavy trucks, which are designed by sculptors to be larger than life (size). Certainly no observer will miss them.



At the marble factory of Gottfried Endres the „angel transport“ (picture above) takes place this time on the road. Therefore the oversized statues had to be dismantled into two parts. A regionally significant event is the Corpus Christi procession on the Lake Staffel (picture below), to which the participating boats are now to be arranged in two rows behind the ferry.

Also the third diorama in the alliance came from him. Here the double-tracked main line leads past the Staffel Lake, which is the location of the events depicted. The regionally known Corpus Christi procession was recreated here, which is staged before the lake front houses with a ferry and boats on the water.

The dream loop module system from Gerhard Maurer celebrated its premiere in Köln. This paper and cardboard artist has already created many buildings completely by himself and set them in beautifully designed landscapes based on real models.



On Gerhard Maurer's dream-loop module system, designed in autumn, we come across a Märklin steam locomotive of the 945-17 class, supersupered by Bahls. It leaves the Kupferhecktunnel with Langenschwalbachers at the hook and now passes the stop Kronweiler.

That was not different here, this time the model was the near distance between Heimbach/Nahe and Kronweiler. This section of the connection Saarbrücken - Mainz leads through the Nahe valley, which is particularly idyllic and worth seeing here. The Heimbach railway station is the visual and operational centre of the new facility.

Bridges to the right and left of it are further eye-catchers on the charmingly laid route. This segment arrangement is also special in that it was deliberately not designed as a summer landscape. This time Gerhard Maurer chose autumn for his work because of the colourful colours and the special appeal they offer.

During the event we were confronted several times with the rumour that the Internationale Modellbahn Ausstellung (International Model Railway Exhibition) was taking place in Köln for the last time. The trigger for these suspicions proved to be the first classification as an exhibition instead of a fair by the city of Köln, according to the organizer without a detailed explanation.

In his opinion, the event fulfils all the requirements of a trade fair in accordance with the trade regulations of the state of North Rhine-Westphalia and should therefore be treated as such again. The term has an impact on Sunday, which without being classified as a trade fair would in principle fall under a sales ban and could make the IMA uninteresting for exhibitors.

“This means that the necessary framework conditions must be created again by the City of Cologne”, says Andreas Wittur, authorised signatory of the organiser Messe Sinsheim. And so everyone involved remains optimistic that there will be a reunion at Koelnmesse from 19 to 22 November 2020.

The official fair pages:

<https://www.modellbahn-koeln.de>

Exhibitors with relevance to Z gauge:

<https://aspenmodel.com>

<http://www.bahls-modelleisenbahnen.de>

<https://bdef.de>

<https://www.busch-model.info>

<https://www.das-kantoor.de>

<https://www.faller.de>

<http://gerhardingen.de>

<https://www.heki-kittler.de>

<http://www.jeweha-modelbouw.be/info%20duitsland.html>

<https://www.kuswa.de>

<https://www.luetke-modellbahn.de>

<https://www.maerklin.de>

<http://microrama.eu>

<https://www.mkb-modelle.de>

<https://www.modellanlagenbau.de>

<https://modellplan.de>

<https://www.mo-miniatur.com>

<https://www.noch.de>

<http://www.peter-post-werkzeuge.de>

<https://www.preiserfiguren.de>

<https://tams-online.de>

<https://shop.train-safe.de>

<https://viessmann-modell.com>

<https://www.z-freunde-international.de>

<http://www.z-lights.de>



Readers' letters and messages

Zetties and Trainini in Dialogue

Thank you for each letter to the editor and all the feedback that reaches us. Write us (contact details see imprint) - Trainini® lives from dialogue with you! Of course, this also applies to all suppliers in Z gauge, who would like to introduce innovations here. A representative image is our goal. Likewise, here we note any events or meetings with a significance to Z gauge reference, if we are informed in time.

A replacement for the **Trainini** Index is the subject of this reader:

I have a version of Acrobat Pro, but this is not the latest one (X); it does not allow index creation. Since I'm not a friend of rental models, I won't switch to Acrobat DC either.

But I would like to present you an alternative solution that I regularly use, for example, in my extensive digital collection of professional literature.

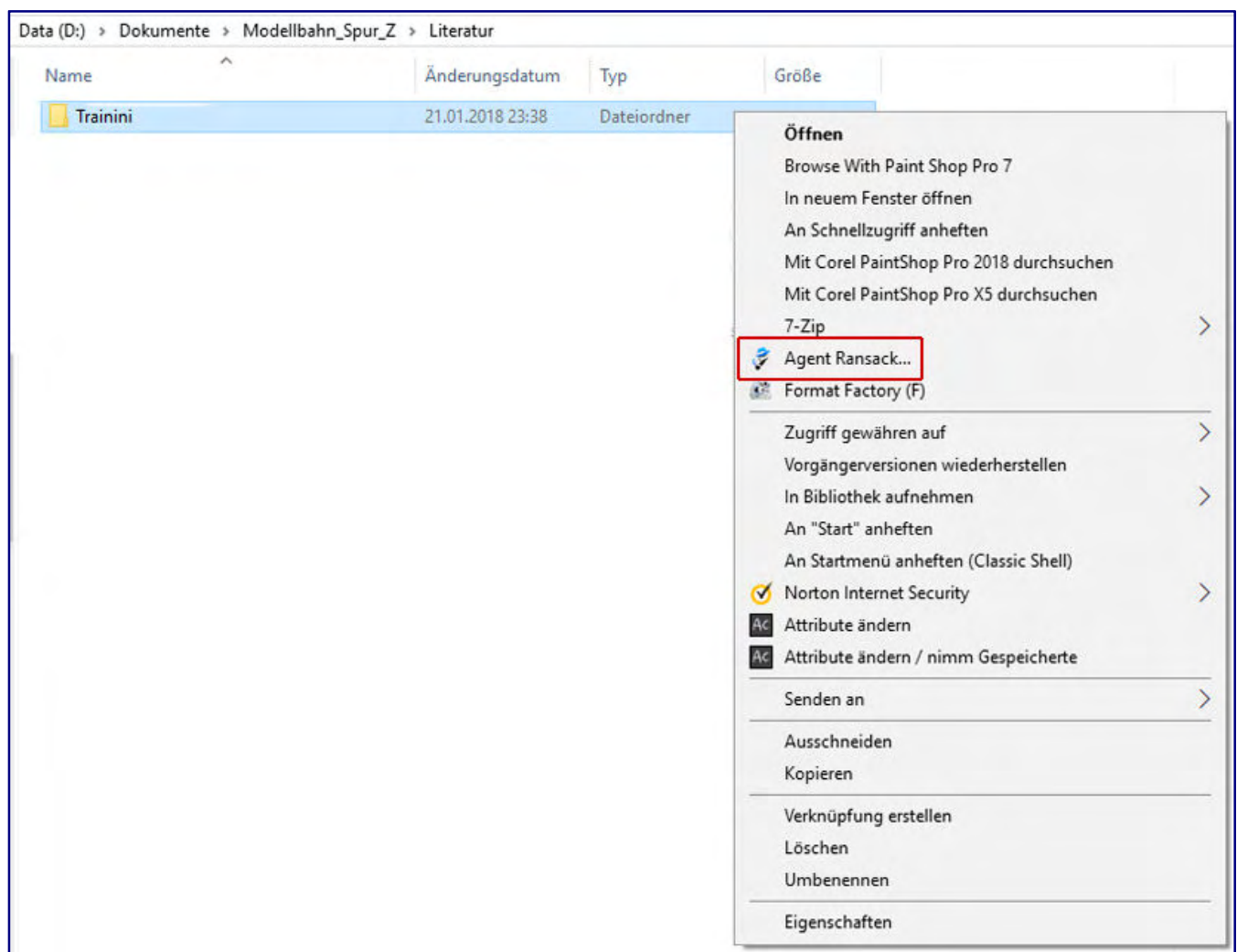

The picture "Agent_Ransack_1.png" shows the integration of "Agent Ransack" into Windows Explorer (red frame). Illustration: Dr. Christoph Ozdoba

Windows has not had a proper search function on board since XP. Since Windows 7 I use a program called "Agent Ransack" (www.mythicsoft.com). It's freeware. The program is integrated into the context menu of the Windows Explorer (picture "Agent_Ransack_1.png").

I did the same search for the article number 81176 in my Trainini directory with Adobe using the index and Agent Ransack (the other two images are).

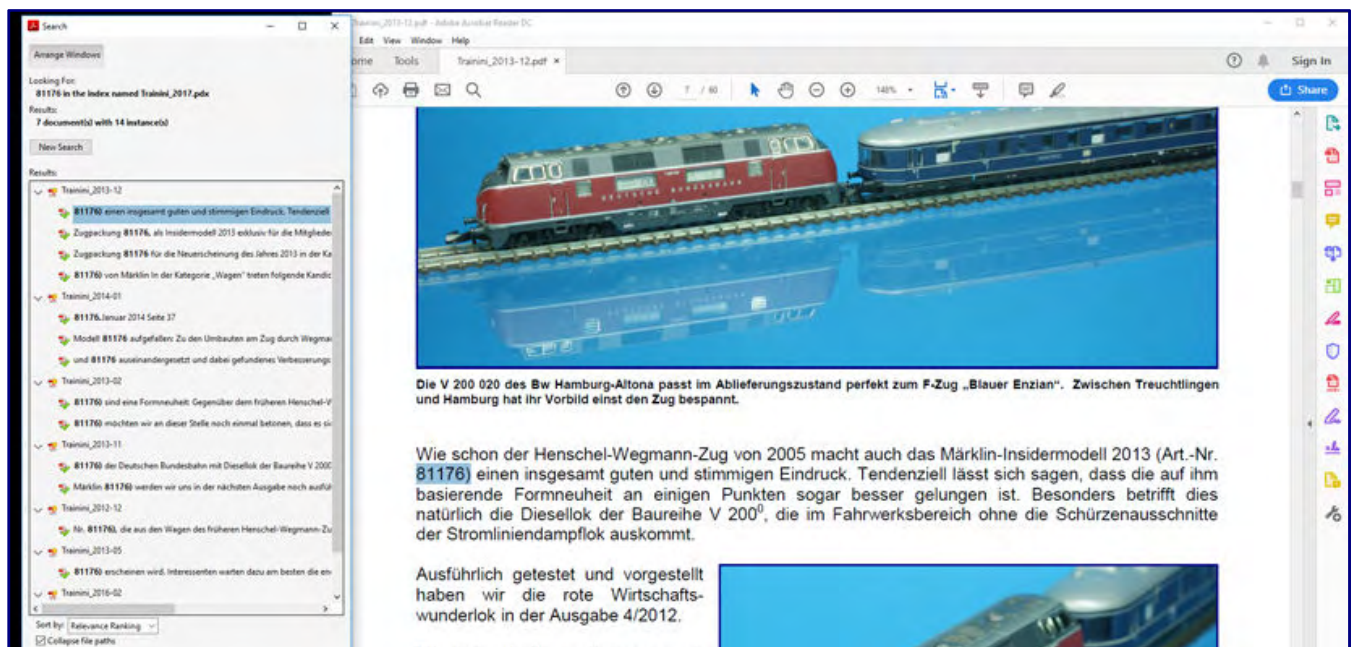
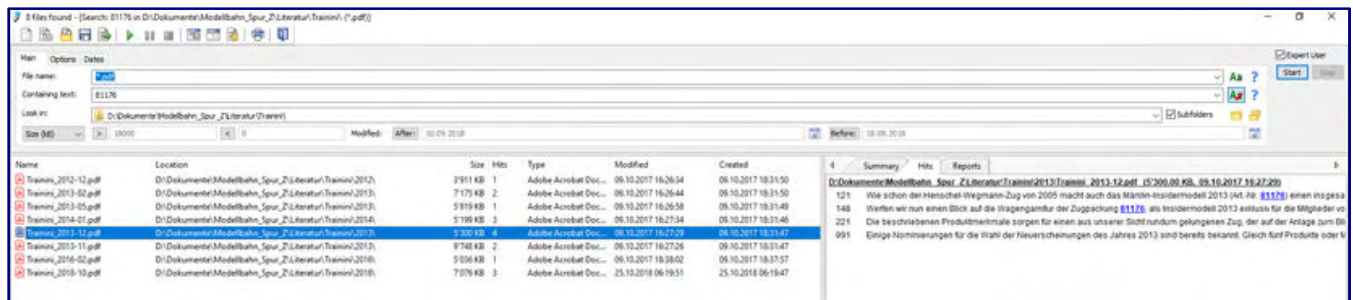

Comparison of the results between Agent Ransack (figure above) and the previous Trainini Index (figure below). Illustration: Dr. Christoph Ozdoba

Sure, with Adobe you have the corresponding text passage directly next to it in the Reader, that's convenient. With Agent Ransack, however, you can set a variety of search parameters, e.g., limit the creation date of the file to a certain period, or search only for a certain year.

Conclusion: Agent Ransack is not quite as convenient as the Adobe index, but overall I don't see it as a workaround, but as a real alternative, especially since it can be used system-wide and for all kinds of documents.

You are welcome to use the images in Trainini if you wish.

With her-Z-lichen greetings and an equally cordial Merci for the great job you do with Trainini.

Dr. Christoph Ozdoba, per E-Mail



Trainini Photo calendar 2019 is ready:

Since the beginning of December, the new **Trainini® Photo Calendar 2019** has been available for interested readers to download and print out themselves. Including the cover picture, 13 attractive Z gauge motifs will sweeten you month after month of the New Year.

Once again, we have chosen carefully in order to accommodate the greatest possible variety of seasonal moods, epochs, traction types and railway administrations in the new edition.

We would like to express our sincere thanks to our readers and supporters for the motifs they supplied.

Like its predecessors, the **Trainini® Photo Calendar 2019** is suitable for a print edition up to DIN A3 landscape format. Particularly good results are achieved when printing on a colour laser printer in a copy shop.

An English version with the official US holidays will follow shortly on the pages of our partner magazine **Ztrack**.

New models from Micro-Trains:

At Micro-Trains, the Christmas business was also used for new deliveries. Thus the wagon number 4 of the yellow Heinz series (Art.-No. 518 00 660) reached the dealers, on which the large, red 57 on the central flap doors is immediately noticeable.

For Oppenheimer Casing & Co. from Chicago, the two wooden refrigerated vehicles (518 00 691 / -692) in brown-green design with advertising along the entire side. The two two-storey livestock transport wagons in green-yellow design (520 00 241 / -242) of the Chicago & North Western from the 1950s are also very old models.

Also expected in December is an aged wagon covered with graffiti with a one-sided large-size design "Pearl Harbor" (510 44 016). In Germany, MTL models can be purchased from Case-Hobbies (<http://case-hobbies.de>), among others.

Nature realistic landscape design with foliage:

The new 20 x 23 cm foils, which can be used in many different areas, have still been delivered to the accessories specialist. They are based on a wafer-thin and highly flexible carrier material, which also permits tearing and application to fissured areas.

It can also be stretched and applied wafer-thin. If you want to create more volume and structure,



The new foils of Noch are easy to tear and give a very realistic picture. Photo: Noch

you can compress and shape it. The classic foil is provided with a fine, naturally coloured flock and is available in three shades of green: light green (Art. No. 07270), dark green (07271) and olive green (07272).

The wild grass foliage is produced by electrostatic flocking, in which various grasses and flakes are combined. It is also available in three shades of green: light green (07280), dark green (07281) and olive green (07282). The meadow foliage is also produced in the same way in three shades of green: yellow-green (07290), medium-green (07291) and dark green (07292).

The leaf foliage, on the other hand, is characterised by flocking with the finely cut Noch foliage. Trees and bushes can be given leaves in two shades of green: medium green (07300) and dark green (07301).

Märklin final spurt in Christmas business:

The DR series 103 (Art.-No. 88771), painted green and black in the lower part of the engine hood, has made it into the delivery, and immediately received a positive response. Contrary to the product illustration, the locomotive, which is technically identical to its predecessors, does not have a raised cooling water compensation tank at the front, but a green painted explosion protection box.

This was a typical feature for the machines from the DR stock, as this series was the only one there with protective devices for operation in hazardous areas.

The locomotive is inscribed with the computer number 103 015-4, which has been valid since 1970.

By the way, its cab roof is also green, and the front with its right-hand slats indicates that the locomotive has been modernised by the East German State Railways.



The newly delivered model of the 103 015-4 (Art. No. 88771) shows typical features of a modernized V 36 from the DR stock. Photo: 1zu220-Shop (Jörg Erkel)

Two further deliveries will be followed by a detailed report.

After all, the two stake cars Rmms 33 of the DB (82130 / 82131), former class district Ulm, from the autumn novelties are complete new constructions, which are by no means identical. They also do not differ only by the existing (82130) or missing load (82131) for the reproduction of straw bales.

The first mentioned car is a model without handbrake, has metal shelves and press plate stanchions, while the sibling model also shows a handbrake platform and still has the wooden shelves and stanchions usual before conversions. Both show replicas of the air brake, however, for the first time with brakes on wheel level. Removable ducts are included as moulded parts. The model 82131 we nominate for the new releases of the year 2018 in the category cars.

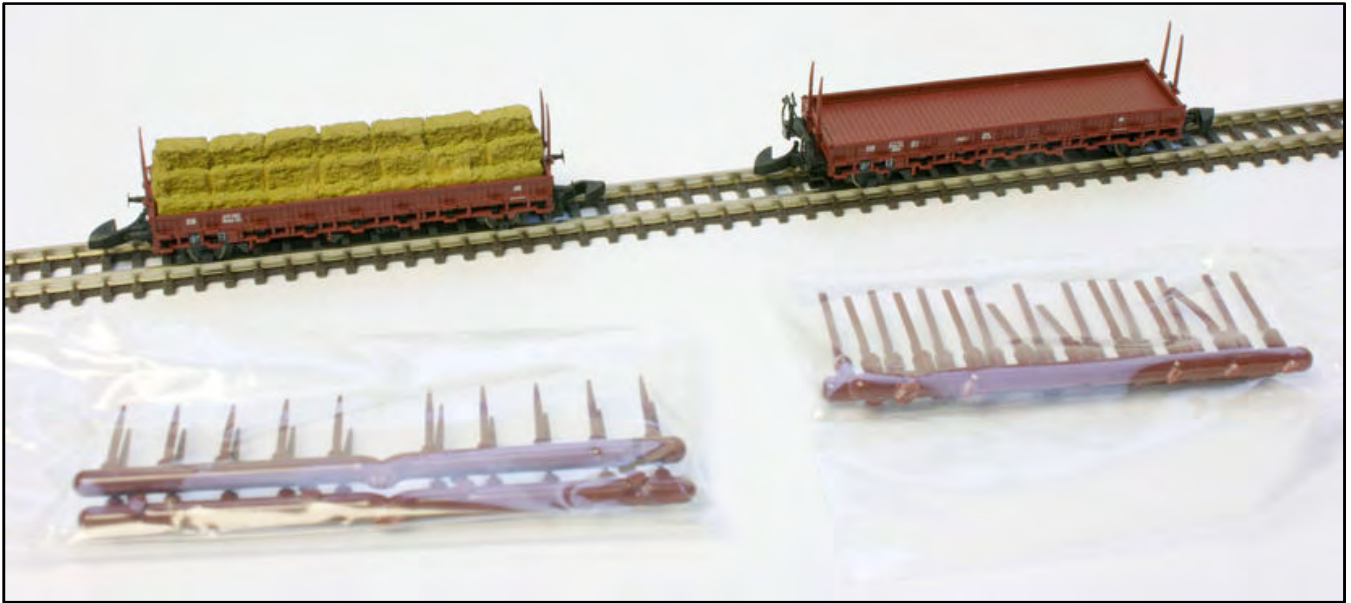

With the Rmms 33, ex Gattungsbezirk Ulm, Märklin has created two variants with a new shape: On the left is the car without handbrake with metal shelves (82130), which is delivered with a load of “straw bales”; on the right is the version with handbrake and wooden shelves (82131). Both models also have two different stanchion (stake) sets included.

A few days before Christmas, the four-part passenger car package (87040) of the Deutsche Bundesbahn was also delivered. It is designed as a small display and contains, each individually packed in transparent boxes, a baggage car Pw3 pr 02) as well as a compartment car 2nd/3rd class BC pr 21 with brakeman's cab, 3rd class C3 Pr 04 and 3rd class C pr 21 without brakeman's cab.



The Prussian compartment coaches (87040) show an as yet unrealised address version at the highest pressure level, but in view of two coaches converted to two-axle coaches with sprinkler system, they also for the first time form a special train variant.

The second and third named wagons with class numbers 21 have only two axles, the others have three. These are conversions of the Deutsche Reichsbahn, where instead of the third axle a sprinkler was mounted to stiffen the car body. Märklin has correctly implemented this with shape changes and thus created a new and interesting variation of the “thousand door trains.”

For the first time, the old Prussian cars are now also equipped with interiors that pick up the wood colour of the hard model benches in a delicate beige. The bottle-green carriages are inscribed in a manner appropriate to the model without the DB logo or emblem and thus correspond to the state of Era IIIa.

Subsequent nominations for the best new releases of the year 2018:

Not all models that stand out from the mass of new products were honoured in detail and with separate reports this year. Therefore, we would like to highlight them once again at this point and nominate the following new deliveries for the individual categories of the award after:

Accessories Category

Combine harvester MF 830 from Artitec (Art. No. 322.018)
Bulldozer Caterpillar D7, yellow from Artitec (322.019)
VW Transporter T1 „Sambabus“ from Zcustomizer (Art. No. unknown)
Port storage building by Modellbau Laffont (Z1701) and
Town hall Quakenbrück from Faller (282774)

Technology Category

Tree-building material “Magitree” from Microrama and the
guided close coupler from SMZ

Literature Category

Güterwagen Band 1.1 / “Freight wagons volume 1.1” (978-3-89610-652-0).

The new products from American Z Line:

At AZL, the SD75i from Union Pacific (Art. Nos. 6102-1 to -3) in particular was delivered from product maintenance. Like the previous versions, it is a new edition with an old housing and a new chassis.



The ATSF, on the other hand, has discontinued the now available AAR cars of covered design with a length of 40 feet. The brown-painted models with black and white lettering are available individually (904300-1), in packs of two (904370-1) and four (914300-1).



The diesel-electric locomotive GE P42 Genesis of Amtrak in Phase III design (63500-1 to -4) was submitted later. This model is available with four service numbers and thus allows almost an own

Fotos: AZL / Ztrack

topic apart from the big freight traffic in the United States. You will find further manufacturer photos of the current deliveries at <http://www.americanzline.com>.

Shinkansen 500 (version V) in special design:

Since 23 November 2018, the Hello Kitty Shinkansen 500 Series from JR West has been available as a Z-gauge model. The model manufactured by Rokuhan is only licensed for the Japanese market and therefore not available in the overseas markets of Europe and America.



Only available in Japan is the Shinkansen 500 "Hello Kitty" from Rokuhan. The three-part basic unit is available individually (Art.-No. T013-6) or as part of a starter kit in special design (G004-3) and can be extended to a realistic prototype length.

In the home market this model was very well received and sold very well, as Rokuhan let us know. Since the model was also reported about in Europe and attracted the attention of Zetties outside Japan, we will report separately about this special train, which has been on the road since April 2018.

We are offering a starter kit (Art.-No. G004-3) with a three-part train, track oval (concrete sleepers), re-railing aid and RC02 driving unit. In addition to the train, the re-railing aid and the running gear also show different colours and special designs. The train is also available individually as a model (T013-6).

Both can be brought to their original length with the aid of a five-part extension pack (T013-7), which brings the high-speed train to the eight-part unit of the V version. The interior lighting systems for Shinkansen models that have already been in the range for a long time are also suitable for this version.

A visit to the northernmost Z-gauge meeting is worthwhile:

The fourth large exhibition of the railway friends Bad Schwartau will take place in January 2010, as we pointed out in the last issue. The organizing association is committed to presenting new exhibits to its audience, which makes a visit particularly worthwhile.

A highlight of the exhibition will certainly be the Z gauge convention in a separate hall, and we also have something new to report on today: Rainer Tielke breathed life into the Märklin kit at Dammtor station. On a new module he has revived the time when trams were still crossing the forecourt. This is completely self-built, including moving cars and trams.



The photo shows the special car that will be sold for the EfS exhibition in January 2019. Photo: EfS / Hans-Jörg Ottinger

Z-gauge car, for which we can finally show a photomontage today, should not be missing either. In the course of history, LMG, the company honoured with this award, has also been active as a supplier to the Lübeck-Büchener Eisenbahn.

All current information including opening hours and admission fees can be found on the event page at https://www.efs-badschwartau.de/2019_ausstellung/.

Track Z novelties at etchIT:

The small series manufacturer etchIT (<http://www.etchit.de>) has recently presented new truck models. The MAN F8 is now available both as a three-axle vehicle with long-haul cabin, swap body and swap platform including tarpaulin (Art. No. XD061_Z) and in the form of a semitrailer tractor. (XD073_Z).



The MAN F8 semitrailer and tractor unit are two of etchIT's latest innovations that are supplied as kits. Photo: etchIT

A finely detailed kit with a cement double silo (XD059z_Z) has appeared as a suitable semi-trailer, with hoses, ladder and grating as replicated features. The interchangeable platform of the first model is also available individually as a load. (XD176a_Z).

Review of the Model Railway Day:

On the occasion of the International Model Railway Day on 2 December 2018, manufacturers and clubs held events throughout Germany to promote the hobby of model railways.

Trainini® did not remain inactive either and took part in the 29th model railway exhibition of the Bergkamener Eisenbahnfreunde (<https://bergkamener-eisenbahnfreunde.jimdo.com>) with a campaign for the youngest. Our handicraft campaign was offered on Sunday with Kristin and Hendrik Späing, who themselves belong to the children's target group and who found even the most promising speech.

Under their expert guidance, the participants were able to transform a beer mat into a small, green landscape and then take it home, free of charge thanks to donations from the model railway shop Modellbahn-Union and 1zu220-Shop as well as the accessories manufacturer Noch and glue manufacturer Uhu.

One or the other acquired a figure or a car model on site and placed it on his artwork.

While the glue of the electro-mechanically dried grass with a Grasmaster 2.0, the participating children were allowed to run a Shinkansen 500 "Project Eva" from Rokuhan over an oval track and pass the time.

Many an adult was amazed at the good driving characteristics and was surprised to hear that even the smallest track can be operated digitally. The strikingly designed train also attracted attention, which led to the question of whether it had a real prototype.

As a small proof of performance for the scale 1:220 and to punish those lies that claimed that details were a privilege of larger gauges, there was the competition diorama "On the Mouse path" from our editor Dirk Kuhlmann available for viewing.

It provided a lot of animated conversation, a lot of recognition and certainly one or the other inspiration in a cross-scale dialogue and with great attraction for all those who had not yet fallen for the model railway virus.



The handicraft offer, supported by various market participants and guided by children, was well received again (top photo). The Shinkansen 500 "Project Eva" was controlled on a Rokuhan oval during the dry glue breaks (Photo below).

We would also like to thank you for smaller donations which we received on site and which we were able to invest in the meantime together with the already existing funds in a Märklin Mobile Station 2, which the children of the model railway working group at the St. John's all-day care of the Albert Schweitzer Elementary School in Schwerte (Ruhr) are now happy about.

In the next months we want to create a fixed shunting game with the pupils of the 3rd and 4th classes, which can be used to promote a very special hobby at school parties and model railway events.

Revised cargo loads by Küpper:

In response to several requests from customers, Spur Z Ladegut Josephine Küpper revised the load for the lift-tipper truck (Märklin 82430 and identical).

The loads for these models are now available in two versions: depending on your choice, it extends to the side wall and ends flush with it (Art. No. Z-154 low) or projects about 1 mm beyond the side wall (Z-153 high).



New at Küpper are brown coal (lignite) load inserts, for the OOtz 43 the inserts are now also two-part. Photo: Spur Z Ladegut J. Küpper

But now we are also thinking about model railroaders who want to recreate opencast mining themes. For them there is now an insert with brown coal (Z-10-3) in the program, which fits into the Märklin model 8630 and identical types.

Helmut Küpper has also challenged the ore wagon OOtz 43 (Märklin 80321): For this wagon the insert is now divided into two parts and takes into account the central bridge (Z-151-2), which makes the appearance even more realistic during transport.

This new item is available exclusively from <https://spur-z-ladegut.de>.

A look ahead to the new year:

Since this year's focus on digital basic knowledge was so well received, and we are planning suitable topics for the future as loose sequels or independent contributions, we are again looking ahead to 2019 as editors.

Here, too, we would like to seamlessly continue a tradition with a new focus topic for the year and focus specifically on special things that are not only of short-term topicality. This series will bear the title "Layout Diversity".

We would like to use it to publish our readers' large stock of outstanding and exceptionally designed plants, to provide them with suggestions and also to make concrete planning suggestions.

Look forward together with us to an exciting 15th edition of your leading practice magazine for Z gauge!

Schrax warms (not only) the hearts:

If the Preiser family would like to offer some barbecues at their garden party, then the new Schrax outdoor fireplace is just in time.

The two-colour 3D print model reproduces a pattern made of concrete and fireclay moulded parts, as it is available in many DIY stores. It can be used to heat logs and prepare food. In this respect, such a model should not be missing from homes on a scale of 1:220. It is available at <http://www.schrax.com>.



Flood of orders and shortage of skilled workers at Märklin:

On 5 December 2018, the Handelsblatt reported on what had already been a topic of conversation between the management and our editorial team in September 2018: Märklin is confronted with a shortage of skilled workers at the Göppingen and Győr sites, which also has serious consequences because the order situation could fully utilise the production capacities.

The new garden grill will be shown here in all sizes produced, including the smallest also for the nominal size Z. Photo: Schrax

Owner Michael Sieber complained after the report that the competitive situation was pulling skilled workers away from the automotive industry. In Filstal, this is particularly the case with the Daimler Group, while Audi operates an engine plant in Győr.

This inevitably leads to bottlenecks, of which Managing Director Florian Sieber is also aware. The focus was therefore placed on young products that have to lie under the tree at Christmas in order not to disappoint the children or even frighten them away. From the experienced collectors the Siebers hope for a little more patience and indulgence.

Aircraft innovations at Herpa:

Herpa has announced its new aircraft models for March and April 2019 in a new brochure design. From them we have again extracted a selection for the scale 1:200:

Tyrolean Airways De Havilland Canada DHC-7 (Art.-Nr. 559553),
German Airforce Transall C-160, LTG 63 Hohn airbase in design "Norm 72" (559560),
Edelweiss Air Airbus A320 in updated colours (559584),
British Midlands Vickers Viscount 800 (559591),
Braniff International Airways Convair CV-340 (559621) and
Crossair Avro RJ100 "Jumbolino" (559638).

Preview of the Museum wagon 2019:

On the evening of 18 December 2018, Märklin once again invited visitors to the preview of the new museum cars for 2019. For the first time, this event took place in the premises of the Märklin museum section opened in September.

This year's partner companies Porsche (for Märklin) and wood dealer Pfeleiderer (for Trix and LGB) were introduced with introductory speeches. The new museum cars were presented finely and decoratively in an arranged shop window, the curtain of which was ceremoniously opened.

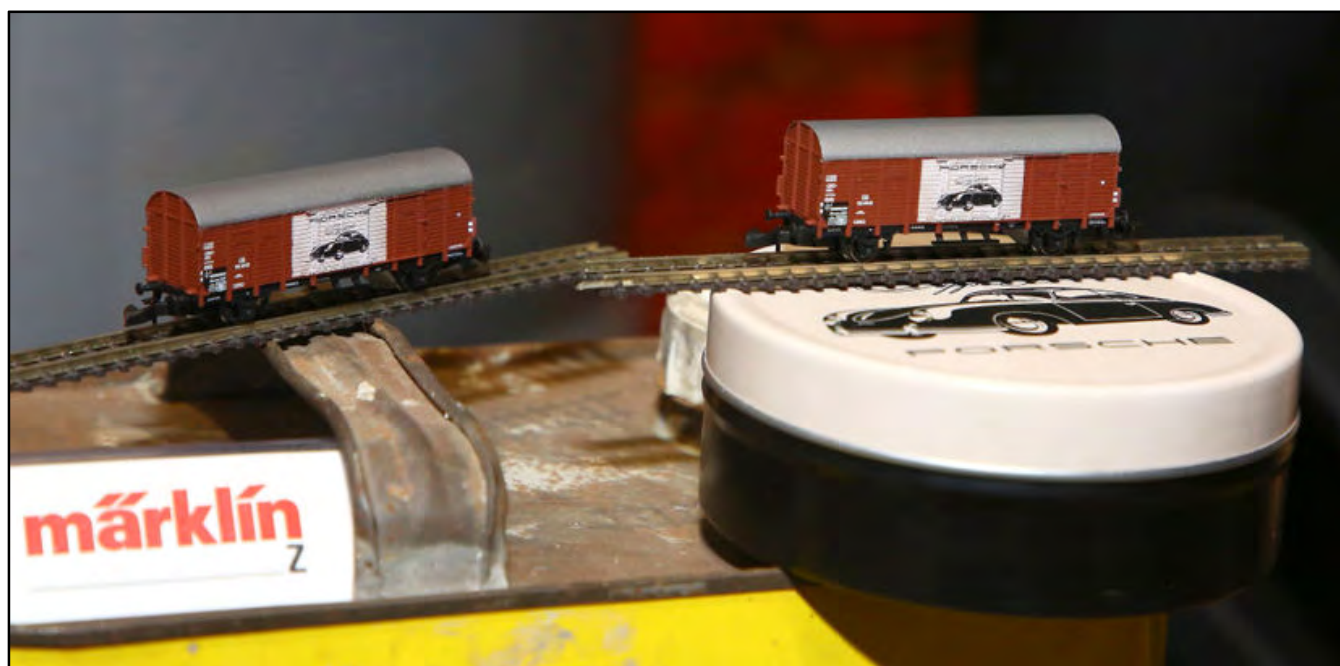

The museum car 2019 for gauge Z is dedicated to the Porsche sports car brand. The G1 11 "Dresden" set at DB is intended to commemorate the transport of parts and vehicles in covered cars, as is particularly evident in the H0 size counterpart.

The museum car 2019 for Z gauge (art. no. 80030) is a covered freight car G1 11 of the DB, former genre district Dresden, with sliding door advertising for Porsche on its way. The motif on the red-brown wagon shows the Porsche 356, an early successful model of the Stuttgart sports car factory. Unfortunately, a car model is not included with the new memento of the visit.

Imprint (Legal Information)

ISSN 2512-8035

Bibliographical information of the German National Library: The German National Library lists this publication in the German National Bibliography. Detailed bibliographic data and editions are available in the DNB catalogue at <https://portal.dnb.de>.

The publication of **Trainini Praxismagazin für Spurweite Z** including **Trainini German Magazine for Z Gauge** is voluntary and non-commercial. **Trainini Praxismagazin für Spurweite Z** does not seek revenue streams. This publication is subject exclusively to German law and justice.

Contributions identified by name reflect solely the personal opinion of the author. This is not necessarily identical with those of editors or publishers. Photos were taken, unless marked differently, by the editorial office.

Editors:

Holger Späing (Editor-in-chief)

Dirk Kuhlmann

Joachim Ritter

North America Correspondent:

Robert J. Kluz

English translations:

Alexander Hock, Christoph Maier, Martin Stercken

Further, volunteer work: Michael Etz (**Trainini Lokdoktor**), Bruno Kaiser, Sujin Ritter, Torsten Schubert, Hendrik J. Späing

Publisher and responsible person under German press law is Holger Späing, Am Rondell 119, 44319 Dortmund; Contact: Tel. +49 (0)231 95987867 or by E-Mail at [redaktion\(at\)trainini.de](mailto:redaktion(at)trainini.de).

Events & advertisements of third parties are free, but are subject to availability & recognizable Z gauge relevance. They appear separately from the editorial part at the sole responsibility of the advertiser. Priority is always given to ads from small series producers.

Letters to the editor must be submitted in writing by mail or e-mail to [leserbriefe\(at\)trainini.de](mailto:leserbriefe(at)trainini.de) stating the full name and address of the responsible reader and are always welcome. The publication remains reserved for the editors. The editors endeavour to always give a representative picture and therefore to consider every entry.

When submitting images, photos and drawings, the transmitter agrees with the publication and exempts the publisher of possible claims by third parties. This includes a future repetition in the magazine, annual video as well as in brochures & posters explicitly.

All company names, trademarks, and designations mentioned in this publication belong to their respective manufacturers or rights holders. Their reproduction takes place without guarantee of the free usability. The editors and publishers assume no liability for misprints, errors, price information, product designations, construction diagrams or transmission errors of any kind whatsoever.

Trainini Praxismagazin für Spurweite Z is published monthly (without guarantee) and is available to all interested model railroaders, especially friends of the Z Gauge, free of charge and for a limited time for download at <http://www.trainini.eu>. Download may incur third party connection and network service provider costs. Posting only the full magazine on other domains is expressly allowed after removal from your own pages, as long as the download is not offered for a fee.

All posts, photos and reports are subject to copyright. Translation, commercial printing and any other kind of reproduction, even in part, assume the prior explicit consent of the publisher. Especially unapproved, commercial exploitation will not be tolerated.

Trainini® is a registered trademark, registered in the register of the German Patent and Trademark Office (Munich), No 307 30 512. Brand owner is Holger Späing, Dortmund, Germany. Misuse will not be tolerated. All rights reserved.